

Safety Precautions

- Important Notes on exporting this product or equipment containing this product;
If the end-user or application of this product is related to military affairs or weapons, its export may be controlled by "Foreign Exchange and Foreign Trade Control Law" of Japan where export license will be required before product can be exported from Japan.
- This product is designed and manufactured for use in General Purpose Industrial Equipment and it is not intended to be used in equipment or system that may cause personal injury or death.
- All servicing such as installation, wiring, operation, maintenance and etc., should be performed by qualified personnel only.
- Tighten mounting screws with an adequate torque by taking into consideration strength of the screws and the characteristics of material to which the product will be mounted. Over tightening can damage the screw and/or material; under tightening can result in loosening.
- Install safety equipment to prevent serious accidents or loss that is expected in case of failure of this product.
- Consult us before using this product under such special conditions and environments as nuclear energy control, aerospace, transportation, medical equipment, various safety equipments or equipments which require a lesser air contamination.
- We have been making the best effort to ensure the highest quality of our products, however, some applications with exceptionally large external noise disturbance and static electricity, or failure in input power, wiring and components may result in unexpected action. It is highly recommended that you make a fail-safe design and secure the safety in the operative range.
- If the motor shaft is not electrically grounded, it may cause an electrolytic corrosion to the bearing, depending on the condition of the machine and its mounting environment, and may result in the bearing noise. Checking and verification by customer is required.
- Failure of this product depending on its content may generate smoke of about one cigarette. Take this into consideration when the application of the machine is clean room related.
- Please be careful when using the product in an environment with high concentrations of sulfur or sulfuric gases, as sulfuration can lead to disconnection from the chip resistor or a poor contact connection.
- Do not input a supply voltage which significantly exceeds the rated range to the power supply of this product. Failure to heed this caution may lead to damage of the internal parts, causing smoke and/or fire and other troubles.
- The user is responsible for matching between machine and components in terms of configuration, dimensions, life expectancy, characteristics, when installing the machine or changing specification of the machine. The user is also responsible for complying with applicable laws and regulations.
- Manufacturer's warranty will be invalid if the product has been used outside its stated specifications.
- Component parts are subject to minor change to improve performance.
- Read and observe the instruction manual to ensure correct use of the product.

Repair	Consult to the dealer from whom you have purchased this product for details of repair work. When the product is incorporated to the machine you have purchased, consult to the machine manufacturer or its dealer
--------	--

URL	Electronic data of this product (Instruction Manual, CAD data) can be downloaded from the following web site; https://industry.panasonic.com/global/en/
-----	--

* MINAS, TUNE COMPASS, Realtime Express and RTEX, the RTEX logo are registered trademarks or trademarks of Panasonic Holdings Corporation in Japan and other countries.
• Realtime Express is a high-speed synchronous motion network developed by Panasonic Holdings Corporation.
• EtherCAT is a patented technology and registered trademark licensed by Beckhoff Automation GmbH in Germany.

● Contact to : _____

Panasonic
INDUSTRY

Panasonic Industry Co., Ltd.,
Industrial Device Business Division

1-1 Morofuku 7-chome, Daito, Osaka 574-0044, Japan



Panasonic
INDUSTRY

Servo System
MINAS A7 Family

MINAS A7

Specification part

IN Better Solution



● This product is for industrial equipment. It cannot be used at general home.

Agile Adaptability

Elevating agile adaptability with man, machine, and application, improves productivity.

Basic performance to further enhance machine performance

Achieves the industry's best motion performance*.

Faithful to the directive, further strong against disturbances.

*As of September 2023, according to our company investigation.

"Optimization of human and machine work by improving servo intelligence"

By making the servo intelligent, makes the setups that has taken man-hours easier by automatic tuning function, expansion of maintenance function, and application optimization.

Improves productivity enhancing agile adaptability of people, machinery, and application.

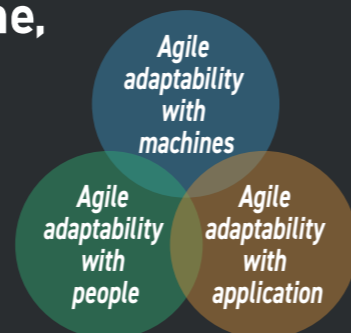

Agile adaptability with machines

Immediate response to commands and disturbances

Moves faithfully to commands and immediately corrects for disturbances with the industry's highest*1 motion performance.

*1 As of September 2023, according to our company investigation.

Encoder resolution: **27 bit**, Speed response frequency: **4.0kHz or higher**,
Maximum motor speed: **7150r/min** *2 For MHMG022

Agile adaptability with people

Immediate response both at startup and in case of trouble

Automatic tuning function is expanded from simple start-up to automation of craftsmanship.

Ultra-high precision **precAlse TUNING** High precision **One Minute TUNING**

Immediate finishing **TUNINGLESS**

Agile adaptability with application

Immediate adaptation to specific application

Controllerless with optimal application functions.

Improves system response by direct sensor feedback control completed in driver.

Displacement control

Pressure control Under development

High precision gantry control Under development

INDEX

A7 Family

- A7 Family Line-up.....3
- Motor List.....6
- Driver List.....7
- How to read product numbers.....8
- Product number correspondence table.....9
- Peripheral equipment configuration.....10
- List of applicable peripherals.....11

Driver

- Driver common specifications..... 12
 - A7B / A7N Series 12
- Functional terminology 14
- Main circuit connection example 16
 - Connectors XA, XB, and terminal block connections 16
- Safety function..... 18
 - Connector X3 connection 18
- Control circuit connection 19
 - Connector X4/X5 connection..... 19
 - Connector X6 connection 20
- Driver external dimensions 22

Motor

- Motor specifications 24
 - Motor specification supplement..... 38

Compliance with EU Directives/UK Standards/UL Standards/KC.... 40

Index.....42

List of overseas sales offices..... 49

MINAS A7



MINAS A7 Line-up

Servo system corresponding to various system configurations

MINAS A7

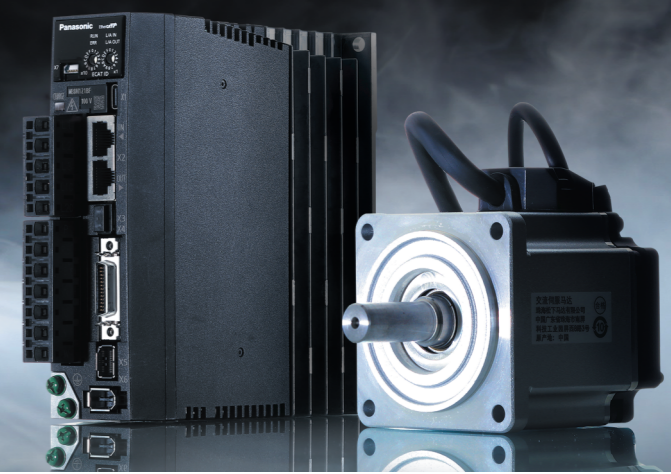

SERVO DRIVER

Rotation type

EtherCAT



Servo driver with open network EtherCAT

MINAS A7B

- Standard type **A7BE**
- Multifunctional type **A7BF**
- Application specialized type **A7BR** Special order

RTEX
Realtime Express



Servo driver with high-speed comm network Realtime Express

MINAS A7N

- Standard type **A7NE**
- Multifunctional type **A7NF**
- Application specialized type **A7NR** Special order

Analog/Pulse train Modbus comms

Under development

MINAS A7S

- Position control type **A7SE**
- Multifunctional type **A7SF**
- Application specialized type **A7SR** Special order

Linear DD motor type

Special order Under development

EtherCAT

- Standard type **A7BL**
- Multifunctional type **A7BM**
- Application specialized type **A7BV**

RTEX
Realtime Express

- Standard type **A7NL**
- Multifunctional type **A7NM**
- Application specialized type **A7NV**

Analog/Pulse train Modbus comms

- Position control type **A7SL**
- Multifunctional type **A7SM**
- Application specialized type **A7SV**

SERVO MOTOR



High inertia

MHMG

- 50 W to 1.0 kW (3000 r/min rated)
- 1.0 kW, 1.5 kW (2000 r/min rated)
- 2.0 kW to 5.0 kW (2000 r/min rated) Under development

Medium inertia

MDMG

- 1.0 kW, 1.5 kW (2000 r/min rated)
- 2.0 kW to 5.0 kW (2000 r/min rated) Under development

Low speed large torque

Medium inertia

MGMG

- 850 W, 1.3 kW (1500 r/min rated)
- 1.8 kW to 4.4 kW (1500 r/min rated) Under development

Low inertia

MSMG

- 50 W to 1.0 kW (□ 80) (3000 r/min rated) Under development
- 1.0 kW (□ 100), 1.5 kW (3000 r/min rated)
- 2.0 kW to 5.0 kW (3000 r/min rated) Under development

EtherCAT/RTEX Controller



Motion Controller

GM1

PLC programming standardized

- EC61131-3 standard compliance, PLCopen, LD/ST/FBD/SFC/IL/CFC

PLC and motion integrated

- Shortest cycle: 500 μs, Multitask control

Expansive communication interface

- RTEX, EtherCAT
- OPC UA server, FTP server
- Ethernet/IP, Modbus, CodesysV3 communication

Support Tools

Servo motor setup support software



It supports the setup of servomotors, setup, test driving, monitoring, maintenance and troubleshooting, with extensive adjustment functions.



Servo motor selection software

This tool is used to select the motor capacity by combination of mechanism elements. Optional items can also be selected.



Motor List



		100 V	200 V
MHMG High inertia 	50 W	40 3000 r/min (7150 r/min)	40
	100 W	40 3000 r/min (7150 r/min)	40
	200 W	60 3000 r/min (6700r/min)	60
	400 W	60 3000 r/min (6700r/min)	60
	750 W		80 3000 r/min (6000r/min)
	1.0 kW		80 3000 r/min (6700r/min) 130 2000 r/min (3000 r/min)
	1.5 kW		130 2000 r/min (3000 r/min)
	2.0 kW		180 2000 r/min (3000 r/min)
	3.0 kW	Under development	180 2000 r/min (3000 r/min)
	4.0 kW		180 2000 r/min (3000 r/min)
5.0 kW		180 2000 r/min (3000 r/min)	
MDMG Medium inertia	1.0 kW		130 2000 r/min (3000 r/min)
	1.5 kW		130 2000 r/min (3000 r/min)
	2.0 kW		130 2000 r/min (3000 r/min)
	3.0 kW	Under development	130 2000 r/min (3000 r/min)
	4.0 kW		180 2000 r/min (3000 r/min)
	5.0 kW		180 2000 r/min (3000 r/min)
MGMG Medium inertia/ Low speed large torque	850 W		130 1500 r/min (3000 r/min)
	1.3 kW		130 1500 r/min (3000 r/min)
	1.8 kW		130 1500 r/min (3000 r/min)
	2.4 kW		180 1500 r/min (3000 r/min)
	2.9 kW		180 1500 r/min (3000 r/min)
	4.4 kW	Under development	180 1500 r/min (3000 r/min)
MSMG Low inertia	50 W	38 3000 r/min (7150 r/min)	38
	100 W	38 3000 r/min (7150 r/min)	38
	200 W	60 3000 r/min (7150 r/min)	60
	400 W	60 3000 r/min (6700r/min)	60
	750 W		80 3000 r/min (6000 r/min)
	1.0 kW		80 3000 r/min (6700 r/min) 100
	1.5 kW		100 3000 r/min (5000 r/min)
	2.0 kW		100 3000 r/min (5000 r/min)
	3.0 kW	Under development	120 3000 r/min (5000 r/min)
	4.0 kW		130 3000 r/min (5000 r/min)
5.0 kW		130 3000 r/min (5000 r/min)	

How to read the table

60 — Flange size
3000 r/min (6700 r/min) — Rated rotational speed (maximum rotational speed)

Driver List



Servo driver with open network EtherCAT

	EtherCAT	Rotation type			Linear DD motor type <small>Special order</small> <small>Under development</small>		
		Standard type A7BE type	Multifunctional type A7BF type	Application specialized type A7BR type <small>Special order</small>	Standard type A7BL type	Multifunctional type A7BM type	Application specialized type A7BV type
Control mode	Position/Speed/Torque Control	●	●	●	●	●	●
	Full closed control		●	●			
Interface	External Scale		●	▲	●	●	●
	Safety connector		●	●		●	●
	Sensor feedback			●			●

▲ : Varies depending on the model. Please contact us for details.

Servo driver with high-speed comm network Realtime Express

	RTEX Realtime Express	Rotation type			Linear DD motor type <small>Special order</small> <small>Under development</small>		
		Standard type A7NE type	Multifunctional type A7NF type	Application specialized type A7NR type <small>Special order</small>	Standard type A7NL type	Multifunctional type A7NM type	Application specialized type A7NV type
Control mode	Position/Speed/Torque Control	●	●	●	●	●	●
	Full closed control		●	●			
Interface	External Scale		●	●	●	●	●
	Safety connector		●	●		●	●
	Sensor feedback			●			●

Analog/Pulse train Modbus

	Rotation type <small>Under development</small>			Linear DD motor type <small>Special order</small> <small>Under development</small>		
	Position control type A7SE type	Multifunctional type A7SF type	Application specialized type A7SR type <small>Special order</small>	Position control type A7SL type	Multifunctional type A7SM type	Application specialized type A7SV type
Control mode	Position control	●	●	●	●	●
	Block operation	External contact Only	External contact or Modbus	External contact or Modbus	External contact Only	External contact or Modbus
	Speed control	●	●	●	●	●
	Internal speed command	External contact Only	External contact or Modbus	External contact or Modbus	External contact Only	External contact or Modbus
Interface	Torque control		●	●	●	●
	Full closed control		●	●		
	Block operation		External contact or Modbus	External contact or Modbus		
Interface	Pulse	●	●	●	●	●
	Analog		●	●		●
	Modbus		●	●		●
	External scale		●	●	●	●
	RS-232, RS-485		●	●		●
	Safety connector		●	●		●
Sensor feedback			●			●

SERVO MOTOR

M H M G 5 A Z U 1 A 2 *

Special specification

Type

- MSM Low inertia
- MDM Middle inertia
- MGM Middle inertia/Low speed large torque
- MHM High inertia

Family

- G A7 Family

Motor rated output

- 5A 50 W
- 01 100 W
- 02 200 W
- 04 400 W
- 08 750 W
- 09 850 W (130 mm sq.), 1000 W (80 mm sq.)
- 10 1000 W
- 13 1300 W
- 15 1500 W

Voltage specification

- 1 100 V
- 2 200 V
- Z 100 V/200 V common (50 W only)

Rotary Encoder Specification

- U Absolute 27 bit 7 wires

Motor structure
80 mm sq. or less MHMG

Symbol	Shaft specification		Holding brake		Oil seal		Motor - encoder terminal Leadwire
	Round	D cut	without	with	without	with	
A 2	●		●		●		●
B 2	●			●	●		●
C 2	●		●			●	●
D 2	●			●		●	●
N 2		●	●		●		●
P 2		●		●	●		●
Q 2		●	●			●	●
R 2		●		●		●	●
S 2			●	●	●		●
T 2			●		●		●
U 2			●	●		●	●
V 2			●		●		●

100 mm sq., 130 mm sq. MSMG, MDMG, MGMG, MHMG

Symbol	Shaft specification		Holding brake		Oil seal		Motor - encoder terminal Connector JN2 Connector JL10 (Small size) (Large size)
	Round	With Key With Tap	without	with	with (protective lip)		
C 5	●		●		●		●
C 6	●		●		●		●
C 7	●		●			●	●
C 8	●		●			●	●
D 5	●		●		●		●
D 6	●		●		●		●
D 7	●		●			●	●
D 8	●		●			●	●
G 5		●	●		●		●
G 6		●	●		●		●
G 7		●	●			●	●
G 8		●	●			●	●
H 5		●		●	●		●
H 6		●		●	●		●
H 7		●		●		●	●
H 8		●		●		●	●

Family
1 Standard product

<Note>
When using as an incremental system (without using multi-rotation data), do not connect the battery for absolute encoder.
Refer to the index page 42 - for the classification of the purchased goods/ ordered goods.

80 mm sq. or less 50 W to 1000 W MHMG : Lead wire type : IP65 equivalent

Motor					Driver		
Motor series	Power supply voltage	Output (W)	Product number Note)1	Specifications External dimensions (Page)	A7B series Product number Note)2	A7N series Product number Note)2	Frame
High inertia MHMG (Lead wire type) 3000 r/min IP65	Single phase 100 V	50	MHMG5AZU1 □ 2	24, 25	MADN061B △△△△	MADN061N △△△△	A frame ★
		100	MHMG011U1 □ 2	24, 25	MADN081B △△△△	MADN081N △△△△	
		200	MHMG021U1 □ 2	26, 27	MBDN121B △△△△	MBDN121N △△△△	B frame ★
		400	MHMG041U1 □ 2	26, 27	MCDN201B △△△△	MCDN201N △△△△	C frame
	Single Phase/ Three Phase 200 V	50	MHMG5AZU1 □ 2	24, 25	MADN065B △△△△	MADN065N △△△△	A frame ★
		100	MHMG012U1 □ 2	24, 25	MADN065B △△△△	MADN065N △△△△	
		200	MHMG022U1 □ 2	26, 27	MADN085B △△△△	MADN085N △△△△	
		400	MHMG042U1 □ 2	26, 27	MBDN125B △△△△	MBDN125N △△△△	B frame ★
		750	MHMG082U1 □ 2	28, 29	MCDN205B △△△△	MCDN205N △△△△	C frame
		1000	MHMG092U1 □ 2	28, 29	MDDN405B △△△△	MDDN405N △△△△	D frame

100 mm sq. 1.0 kW to 1.5 kW MSMG : Connector type : IP67 equivalent

Motor					Driver		
Motor series	Power supply voltage	Output (W)	Product number Note)1	Specifications External dimensions (Page)	A7B series Product number Note)2	A7N series Product number Note)2	Frame
Low inertia MSMG (Connector type) 2000 r/min IP67	Single Phase/ Three Phase 200 V	1000	MSMG102U1 □□	32, 33	MDDN405B △△△△	MDDN405N △△△△	D frame
		1500	MSMG152U1 □□	32, 33	MDDN405B △△△△	MDDN405N △△△△	

130 mm sq. 850 W to 1.5 kW MHMG, MDMG, MGMG : Connector type : IP67 equivalent

Motor					Driver		
Motor series	Power supply voltage	Output (W)	Product number Note)1	Specifications External dimensions (Page)	A7B series Product number Note)2	A7N series Product number Note)2	Frame
High inertia MHMG (Connector type) 2000 r/min IP67	Single Phase/ Three Phase 200 V	1000	MHMG102U1 □□	30, 31	MCDN245B △△△△	MCDN245N △△△△	C frame
		1500	MHMG152U1 □□	30, 31	MDDN405B △△△△	MDDN405N △△△△	D frame
Medium inertia MDMG (Connector type) 2000 r/min IP67	Single Phase/ Three Phase 200 V	1000	MDMG102U1 □□	34, 35	MCDN245B △△△△	MCDN245N △△△△	C frame
		1500	MDMG152U1 □□	34, 35	MDDN405B △△△△	MDDN405N △△△△	D frame
	Single Phase/ Three Phase 200 V	850	MGMG092U1 □□	36, 37	MCDN245B △△△△	MCDN245N △△△△	C frame
		1300	MGMG132U1 □□	36, 37	MDDN405B △△△△	MDDN405N △△△△	D frame

★ : Regenerative resistance is not built into driver for frame A and B types. If regeneration occurs, prepare optional external regenerative resistors.
Note)1 □ represents the motor structure. For details, see "How to read product numbers" on page 8.
Note)2 △ represents driver feature. For details, see "How to read product numbers" on page 8.
See the separate "Options part"

SERVO DRIVER

M A D N 0 6 5 N E * * *

Exclusive specification

Outer frame symbol

- MAD A frame
- MBD B frame
- MCD C frame
- MDD D frame

Family

- N A7 Family

Maximum current rating

- 06 6 A
- 08 8 A
- 12 12 A
- 20 20 A
- 24 24 A
- 40 40 A

Power supply voltage specifications

- 1 Single phase 100 V
- 3 Three phase 200 V
- 5 Single Phase/Three Phase 200 V

Special specification

- 0 For special products of standard type and multi-functional type
- H Gantry control type (under development)
- T Pressure control type (under development)
- U Meandering control, GAP control supported

Classification of type

- E Rotational standard type No Safety
- F Rotational multifunctional type Safety STO
- R Rotational application specialized type Safety STO

Command interface specification

- B EtherCAT
- N RTEX

A7B / A7N series (Driver : B frame Motor 200 W)

*The picture is "A7B B frame."

Main circuit wiring

Connecting the main power supply

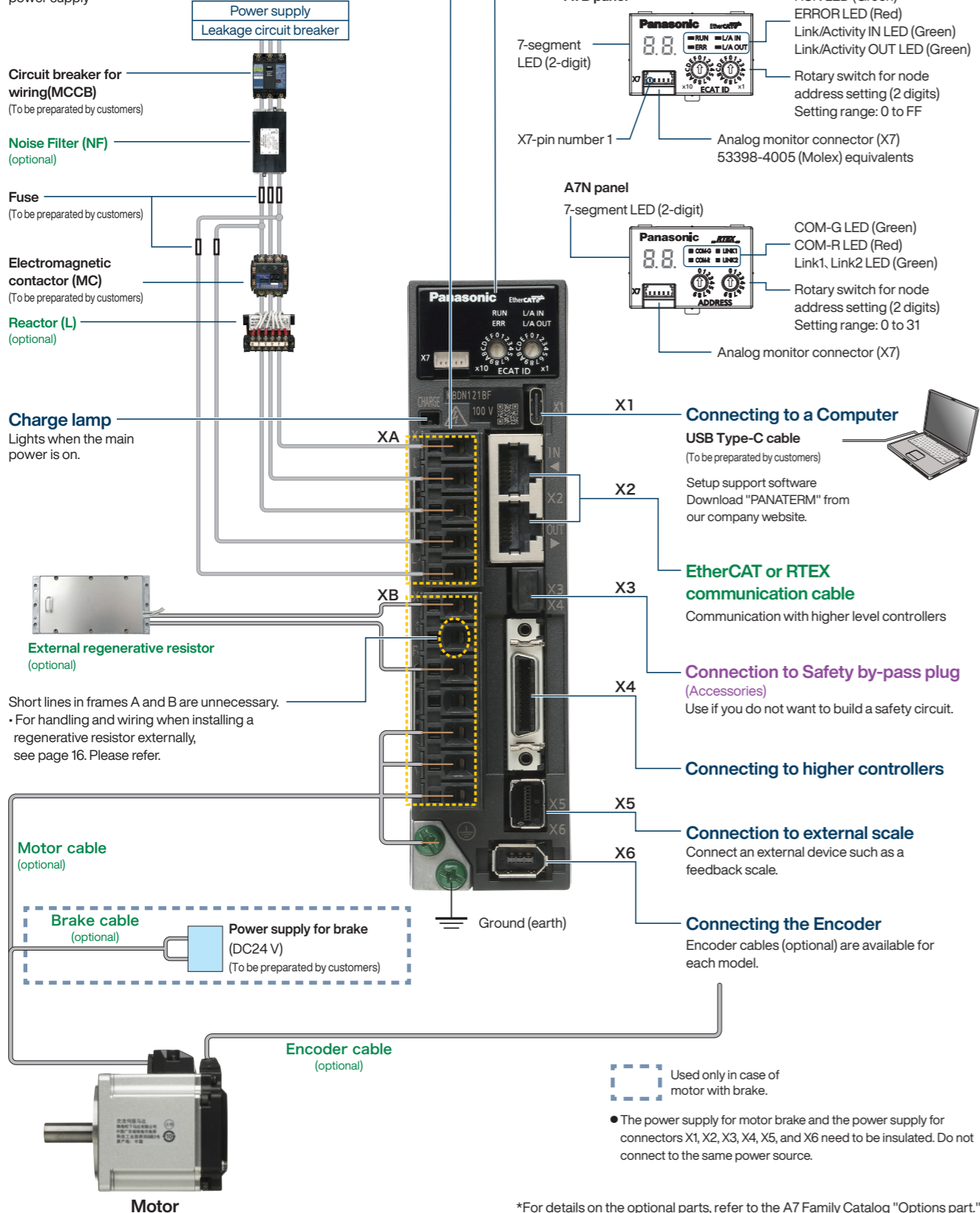

*For details on the optional parts, refer to the A7 Family Catalog "Options part."

<Caution>

Please select the appropriate tightening torque for the product's mounting screws, taking into consideration the strength of the screws used and the material to which they are attached, to avoid loosening or damage.
Example) When tightening steel screws (M5) to steel, 2.7 N·m to 3.3 N·m.

Driver	Applicable motor	Voltage specification (V) ^{*1}	Rated output (W)	Power supply capacity (at rated load) (kVA)	Circuit breaker (Rated current) (A)	Short circuit protection element (Fuse) (A)		Noise filter (Single Phase/Three Phase)	Ferrite core	Electro-magnetic contactor (A) ^{*2}	Conductor thickness for main circuit Withstand voltage	Terminal block crimp terminal for main circuit ⁻³	Wire thickness for control power supply	Terminal block crimp terminal for control power supply	Motor wire thickness Withstand voltage ^{*6}	Terminal block crimp terminal for motor ⁻⁴	Brake wire thickness Withstand voltage ⁻⁵	
						Main circuit power input line	Control circuit power input line											
MADN	Single Phase 100		50	Approx. 0.4	10			DVOP4170 (Single phase only)										
MBDN			100															Approx. 0.5
MCDN			200															Approx. 0.9
MADN	MHMG		50	Approx. 0.5	15	10		DVOP4170 (Single phase only)	20 (3P+1a)									
MBDN			100															Approx. 0.6
MCDN			200															Approx. 1.0
MADN	Single Phase/Three Phase 200		750	Approx. 1.9	20			DVOP20042										
MBDN			850															Approx. 2.4
MCDN			1000															Approx. 2.9
MADN	MSMG, MDMG, MIMG, MHMG		1000	Approx. 2.4	35			DVOP4220	32 (3P+1a)									
MBDN			1300															Approx. 2.9
MCDN			1500															Approx. 2.9

- *1 For single phase/three phase 200 V common specifications, select peripheral equipment according to the power supply used.
 - *2 The electromagnetic contactor used for the external dynamic brake resistor should have the same rating as the electromagnetic contactor used for the main circuit.
 - *3 Use the same crimp terminal for the ground screw as the crimp terminal for the main circuit terminal block.
 - *4 Make sure that the thickness of the ground wire and the external dynamic brake resistor wire are the same or larger than the motor wire.
 - *5 For UL certification, in the case of a single phase power supply, please use a clamp meter that can measure the effective value current and derate the input effective current to 12A or less.
 - *6 Applicable wire size varies depending on the motor model number. Please check the instruction manual or specifications document for the applicable wire size for each motor model number.
- ※ Specifications are subject to change due to improvements, etc. Please be sure to obtain the latest information when using these products.

● Circuit breakers and electromagnetic contactors

To comply with EU directives/UK standards, be sure to connect an IEC standard and UL certified (LISTED, marked) molded circuit breaker between the power supply and the noise filter.
Make sure that the short-circuit current of the power supply you use is less than 5000 Arms symmetrical current when the product's maximum input voltage is less than that. If the short-circuit current of the power supply exceeds this, install a current-limiting device (current-limiting fuse, current-limiting breaker, transformer, etc.) to limit the short-circuit current.

<Caution>

- Select a molded circuit breaker and noise filter with a capacity commensurate with the power supply capacity (taking load conditions into consideration).

● Terminal block and protective ground terminal

- Use copper conductor wires with a temperature rating of 75 °C or higher for wiring.
- For frames A to D, use the included dedicated connectors. In that case, keep the length of the stripped wire between 8 mm and 9 mm.

■ Driver: tightening torque

(Connection connector [X4] with ground screw and upper controller)

Driver external frame symbol	Ground screw		Connector to upper controller (X4)	
	Call	Tightening torque(N·m) Note)1	Call	Tightening torque(N·m) Note)1
MADN, MBDN, MCDN, MDDN	M4	0.7 to 0.8	M2.6	0.2 ± 0.05

- Note)1 <Caution>
- Exceeding the maximum tightening torque may cause damage.
 - Do not turn on the power while the terminal block screws are loose.
 - Turning the power on while the screws are loose may cause smoke or fire.

<Remarks> Check the tightening torque periodically once a year for looseness.

Item		A7B	A7N
Input power	100 V series	Main circuit power supply	Single Phase 100 V +10% to 120 V +10% -15% -15% 50/60 Hz
		Control circuit power supply	Single Phase 100 V +10% to 120 V +10% -15% -15% 50/60 Hz
	200 V series	Main circuit power supply	Single Phase/Three Phase 200 V +10% to 240 V +10% -15% -15% 50/60 Hz
		Control circuit power supply	Single Phase 200 V +10% to 240 V +10% -15% -15% 50/60 Hz
Ambient conditions of use	Temperature	Operating temperature: 0 to 60 °C (Can be used at reduced rating if 55 to 60 °C) (No freezing) Storage temperature: -20 to 65 °C (Maximum temperature guaranteed: 80 °C, 72 hours, non-condensing *)	
	Humidity	Use, Storage Humidity: 20 to 85% RH or Less (No Condensation *)	
	Elevation	Below 2000 m above sea level (can be used with reduced rating for 1000 to 2000 m)	
	Vibration	5.88 m/s ² or less, 10 to 60 Hz	
	Degree of contamination	Degree of contamination 2	
	Mounting space	10 mm or more (1 to 10 mm can be used with reduced rating **)	
Protection class		IP00	
Insulation voltage		Withstand AC1500V for 1 minute between 1st side and earth	
Control method		IGBT PWM method Sine wave drive	
Encoder feedback		27 bit (134217728 resolution) 7-wire serial absolute encoder	
External scale feedback *3		A/B phase/home signal differential input type Panasonic industry serial communication type *4	
Control signal	Input	General purpose 8 inputs General-purpose input functions are selected by parameters	
	Output	General purpose 3 outputs General-purpose output functions can be selected by parameters	
Analog signal	Input	1 input (16-bit A/D : input)*5	
	Output	2 outputs (Analog monitor 1, Analog monitor 2)	
Pulse signal	A/B phase output (2 outputs)	Line driver output with A/B phase signal	
	Position compare output (3 outputs)	When the actual position passes the position set by the parameter, the line driver outputs a pulse signal.	—
Communication function	Realtime Express (RTEX)	—	Real-time operation command transmission, parameter setting, status monitoring, etc. possible
	EtherCAT	Real-time operation command transmission, parameter setting, status monitoring, etc. possible	—
	USB	Parameter settings, status monitoring, etc. possible by connecting a PC, etc.	
Safety function *3		Safe Torque Off (STO) 2 Input (Safety Input 1, 2) 1 Output (EDM output)	
Front panel		① Rotary switch ② LED 7 segment 2 digits and 4 lights for status display ③ Connector for analog monitor	
Regenerative		A, B frame: No built-in regenerative resistor (external only) C, D frame: Built-in regenerative resistor (external connection is also possible)	
Dynamic brake		Frame A-D: Built-in	
Control mode		Position control: Profile position control (pp), cyclic position control (csp), homing position control (hm) Speed control: Profile speed control (PV), cyclic speed control (CSV) Torque control: profile torque control (tq), cyclic torque control (cst) The above control modes can be switched using EtherCAT communication commands.	Position control: cyclic position control (CP)

*1 Please note that condensation is more likely to occur as the temperature drops.
*2 When using the servo driver at an ambient temperature of 55 to 60 °C or at an altitude of 1000 to 2000 m, use the load factor multiplied by the respective load factors shown in the figure on the right. When using a servo driver with a mounting interval of 1 to 10 mm, refer to the ambient temperature shown in the figure on the right.
*3 Not available for standard types.
*4 Please refer to the separate collaboration catalog for compatible scale manufacturers and product numbers.
*5 Available for only application specialized type. (Special order)

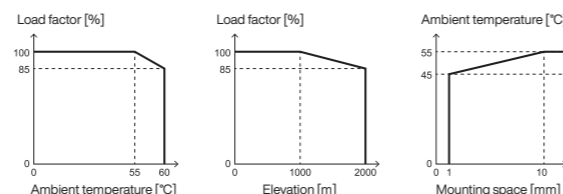

Mode	Item	A7B	A7N
Position control	Control input	Positive direction over-travel inhibit, negative over-travel inhibit, latch signal, near origin, etc.	
	Control output	Positioning completion, etc.	
	Command input	EtherCAT command type (smoothing filter available)	RTEX command type (smoothing filter available)
	Basic functions	Rotation direction setting, Command input, Electronic gear, Motor movable range setting, Regenerative resistance setting, Absolute setting, External scale type selection, 2 degrees of freedom control mode	Rotation direction setting, Command input, Electronic gear, Motor movable range setting, Regenerative resistance setting, Absolute setting, External scale type selection, 2 degrees of freedom control mode, Network setting (communication cycle/command update cycle setting)
	Tuning function	Real-time auto-tuning, Adaptive filter, Gain switching, 3rd gain switching, Notch filter, Vibration damping control, Model-type damping filter, Speed feedforward, Torque feedforward, Load fluctuation compensation, Friction torque compensation, Two-stage torque filter, Quadrant glitch compensation, Position command filter, High response current control, Backlash correction	
Applied function	Pulse regeneration, Deceleration stop, Over travel inhibit (POT, NOT), Deceleration stop, Deceleration stop at Servo-Off, Deceleration stop at main power off, Deceleration stop at alarm, Immediate stop at alarm, Fall prevention at alarm, Fall prevention at Servo-On, Derating, Torque limit switching, Torque saturation protection, Position compare output (A7B only), 1 rotation absolute, Infinite rotation absolute, External scale position information monitor during semi-closed control, Slow stop		
Speed control	Control input	Positive direction over-travel inhibit, Negative direction over travel inhibit, latch signal, etc.	
	Control output	At-Speed, Speed coincidence, etc.	
	Command input	EtherCAT command type	RTEX command type
	Basic functions	Rotation direction setting, Command input, Electronic gear, Regenerative resistance setting, Absolute setting, 2 degrees of freedom control mode, External scale type selection	Rotation direction setting, Command input, Electronic gear, Regenerative resistance setting, Absolute setting, 2 degrees of freedom control mode (speed), External scale type selection, Network setting (communication cycle/command update cycle setting)
	Tuning function	Real-time auto-tuning, Adaptive filter, Gain switching, Notch filter, Torque feedforward, Load fluctuation compensation, Friction torque compensation, Two-stage torque filter, Speed command acceleration/deceleration setting, High-response current control	
Applied function	Pulse regeneration, Deceleration stop, Over travel inhibit (POT, NOT), Deceleration stop at Servo-Off, Deceleration stop at main power off, Deceleration stop at alarm, Fall prevention at alarm, Fall prevention at Servo-On, Derating, Torque limit switching, Torque saturation protection, Position compare output (A7B only), 1 rotation absolute, Infinite rotation absolute, External scale position information monitor during semi-closed control, Slow stop		
Torque control	Control input	Over travel inhibit (positive, negative direction, latch signal, etc.)	
	Control output	At-Speed, etc.	
	Command input	EtherCAT command type	RTEX command type
	Basic functions	Rotation direction setting, Command input, Electronic gear, Regenerative resistance setting, Absolute setting, External scale type selection, 2 degrees of freedom control mode, Speed limit	Rotation direction setting, Command input, Electronic gear, Regenerative resistance setting, Absolute setting, External scale type selection, Speed limit, 2 degrees of freedom control mode
	Tuning function	Real-time auto tuning, Gain switching, Notch filter, Two-stage torque filter, High-response current control, Torque feedforward, Friction torque compensation	
Applied function	Pulse regeneration, Deceleration stop, Deceleration stop at over travel inhibit (POT, NOT), Deceleration stop at Servo-Off, Deceleration stop at main power is off, Deceleration stop at alarm, Immediate stop at alarm, Fall prevention at alarm, Fall prevention at Servo-On, Derating, Torque limit switching, Position compare output, 1 rotation absolute, Infinite rotation absolute, External scale position information monitor during semi-closed control, Slow Stop		
Full closed control	Control input	Positive direction over travel inhibit (POT, NOT), Negative direction over travel inhibit (POT, NOT), Latch signal, Near origin, etc.	
	Control output	Positioning complete, At-speed output, Speed matching output, etc.	
	Command input	EtherCAT command type (smoothing filter available)	RTEX command type (smoothing filter available)
	Basic functions	Setting rotation direction, command input, Electronic gear, Motor moving range setting, Regenerative resistance setting, External scale type selection, 2 degrees of freedom control mode, External scale division ratio setting, Hybrid deviation excess setup	Rotation direction setting, Command input, Electronic gear, Motor movable range setting, Regenerative resistance setting, External scale type selection, 2 degrees of freedom control mode, External scale division ratio setting, Hybrid deviation excess setting, Network setting (communication cycle and command update cycle setting)
	Tuning function	Real-time auto tuning, Adaptive filter, Gain switching, Third gain switching, Notch filter, Damping control, Speed feedforward, Torque feedforward, Load fluctuation suppression, Friction torque compensation, Hybrid vibration suppression, Two-stage torque filter, Quadrant glitch compensation, Position command filter, High response current control, Backlash compensation	
Applied function	Pulse regeneration, Deceleration stop, Deceleration stop at over travel inhibit (POT, NOT), Deceleration Stop at Servo Off, Deceleration stop at main power off, Deceleration stop at Alarm, Immediate stop at alarm, Fall prevention at alarm, Fall prevention at Servo-On, Derating, Torque limit switching, Torque saturation protection, Position compare output (A7B only), External scale position information monitor during Semi-Close Control		
Common	Safety function	STO	
	Protection function	Protection stop, Warning, Timestamp	

*For a description of each function name (functional terminology), see the following page.

*Each specification is subject to change for improvement. Be sure to obtain the latest manual when actually using this product.

Functional terminology

Class	Function name	Functional overview	
Output/Input	Positioning complete output (INP, INP2)	A function for outputting positioning completion output (INP) or positioning completion output 2 (INP2), which is an external output signal, in the positioning completion state.	
	At-speed output	A function that outputs an external output signal, the speed reaching output (AT-SPEED) signal, when the motor speed exceeds a set speed.	
	Speed coincidence output	A function for outputting the speed coincidence output (V-COIN), which is an external output signal, when the speed command and the motor speed coincide.	
Basic	Rotation direction setting	Function to set the direction of motor rotation with respect to the direction of position command, speed command and torque command.	
	Command input	Operation commands using RTEX communication commands and EtherCAT communication objects	
	Electronic gear	A function that multiplies the position/speed command input from the host device by the electronic gear ratio set in a parameter or object and make it the position/speed command to the position/speed control block.	
	Motor movable range setting	A function that generates an alarm and decelerates and stops the motor when the motor position exceeds the movable range.	
	Regenerative resistance setting	A function to switch the settings of the regenerative resistance load protection function.	
	Absolute setting	A function to set how to use the absolute encoder.	
	External scale type selection	A function to select the type of external scale used and set direction reversal for the external scale feedback counter.	
	Two-degree-of-freedom control	Expanded function for each control mode that improves responsiveness by allowing command response and servo stiffness to be set independently.	
	Speed limit	As a protection during torque control, this function controls the speed so that it does not exceed the speed limit value set during torque control.	
	External scale division ratio setting	A function to set the division ratio for encoder resolution and external scale resolution.	
	Hybrid deviation excess setting	A function that detects the difference between the motor (encoder) position and the load (external scale) position, and generates hybrid deviation excess error protection when the difference exceeds the allowable value.	
	Network setting	Function for setting the RTEX communication cycle and command update cycle.	
	Tuning	Real-time auto tuning	A function that estimates the load characteristics of a machine in real time and automatically performs basic gain settings and load fluctuation compensation according to stiffness parameters based on the estimation results.
		Adaptive filter	A function that reduces vibration by estimating the resonance frequency from the vibration component that appears in the motor speed under actual operating conditions and removing the resonance component from the torque command.
Gain switching		A function that switches the gain using a switching command depending on the operating state.	
Third gain switching		A function to set a third gain that switches the gain just before stopping, in addition to the normal gain switching function.	
Notch filter		The function of setting a filter to suppress the resonance peak of the machine.	
Damping control		A function that reduces vibration by removing vibration frequency components from position commands when the tip of the device vibrates or the entire device shakes.	
Model type damping filter		A function that improves the effectiveness of vibration control and reduces vibration by removing anti-resonance frequency components and resonance frequency components when the tip of the device vibrates or the entire device shakes.	
Speed feedforward		A function that increases the responsiveness of position control by reducing position deviation during operation at a constant speed using a speed feedforward value.	
Torque feed forward		A function that increases the response of speed control by using the torque feedforward value to bring the position error closer to 0 during acceleration/deceleration.	
Load fluctuation compensation		A function that suppresses motor speed fluctuations due to disturbance torque and load fluctuations and improves stability.	
Friction torque compensation		A function that reduces the effects of friction that exists in mechanical systems.	
Hybrid vibration suppression		A function that suppresses vibration caused by the twist between the motor and load in full-closed control mode.	
Two-stage torque filter		A function that sets another torque filter to increase the effect of suppressing high-frequency vibration components besides 1st and 2nd torque filter.	
Quadrant glitch compensation		A function that suppresses quadrant glitch that occurs during circular interpolation operation on two or more axes.	
Position command filter		A function to smooth the position command after electronic gear.	
Speed command acceleration/deceleration setting		A function that automatically applies acceleration and deceleration to speed control in response to speed command input.	
High response current control		A function that improves the responsiveness of the current control part by changing the current response setting to a value larger than the factory setting.	
Backlash compensation		Function to compensate backlash during position control (including full close control).	

Class	Function name	Functional overview
Application	Torque limit switching	A function that switches the torque limit value according to the operating direction or the torque limit switching command (TL_SW) of RTEX communication.
	Torque saturation protection	A function that generates an alarm when torque saturation continues for a certain period of time.
	Position compare output	A function that outputs a pulse signal from the general-purpose output or position compare output terminal when the actual position passes the position set by the parameter.
	1 rotation absolute	A function that allows the absolute encoder to be used as an absolute system with only one revolution.
	Infinite rotation absolute	A function for arbitrarily setting an upper limit value of multiple rotation data of an absolute encoder.
	Pulse regeneration	A function that outputs the actual position movement amount as AB phase pulses.
	Virtual full closed control	A function that virtually estimates the external scale position from encoder position information and allows axis operation to continue.
	External scale position information monitor during semi-closed control	A function to monitor external scale position information using RTEX communication and EtherCAT object during semi-closed control.
	Retracting operation	A function to activate the evacuation operation by turning off the main power or inputting an evacuation operation signal, and to set the operation details.
	Deceleration stop	A function to set the motor deceleration and stop method when the main power is cut off or an alarm occurs.
	Deceleration stop at over travel inhibit input (POT, NOT)	A function to set the operation during deceleration and after stopping after inputting over travel inhibit input (POT, NOT).
	Deceleration stop at Servo-Off	A function to set the stopping method during deceleration at Servo-Off, and the operation after stopping.
	Deceleration stop at main power off	A function to set the stopping method during deceleration and the operation after stopping after the main power is turned off.
	Deceleration stop at alarm	A function to set the stopping method during deceleration at alarm and the operation after stopping.
	Immediately stop when alarm occurs	A function to set the stop action when an immediate stop alarm occurs.
	Fall prevention when alarm occurs	A function that prevents falling at alarm by setting the alarm deceleration stop function to immediate stop.
	Fall prevention at Servo-On	A function that eliminates the delay in the rise of the torque command at Servo-On command input and prevents the device from falling.
	Slow Stop	A function that smoothly stops the motor with Servo-On when the main power is turned off or an alarm occurs with the immediate stop setting.
	Derating	A function to derate the overload characteristics of the servo driver according to the derating magnification set by the parameter.
	Displacement control	A function that directly inputs a displacement sensor signal to a servo driver, achieving a constant clearance within the driver even for workpieces with varying heights, with high responsiveness.
Safety	Safety, STO	A function that cuts off the motor current and turns off the motor output torque by forcibly turning off the drive signal of the power transistor inside the servo driver using a circuit (hardware) from the safety input signal.
Protection	Protection	A function that detects equipment abnormalities and stops the motor to ensure safety.
	Warning	A function that generates a warning before the protection function operates and checks conditions such as overload in advance.
	Timestamp	A function that adds the time alarm occurred to the alarm information, and also adds the measurement time to the waveform information measured using the waveform graphic function provided by the setup support software.

*These descriptions are terminology explanations and are not a list of the actual features included.

Main circuit connection example Connectors XA, XB, and terminal block connections

For A frame, B frame single phase 100 V, 200 V

●For lead wire type motor

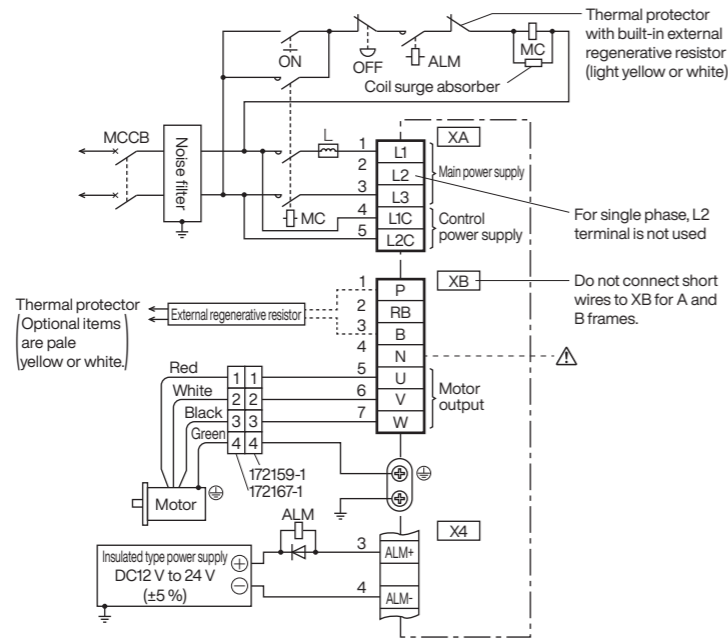

● Pin No. descriptions of X4 are based on shipping parameters.

*The motor brake power supply and connector X4 power supply must be insulated. Do not connect them to the same power source.

For C frame, D frame single phase 100 V, 200 V

●For lead wire type motor

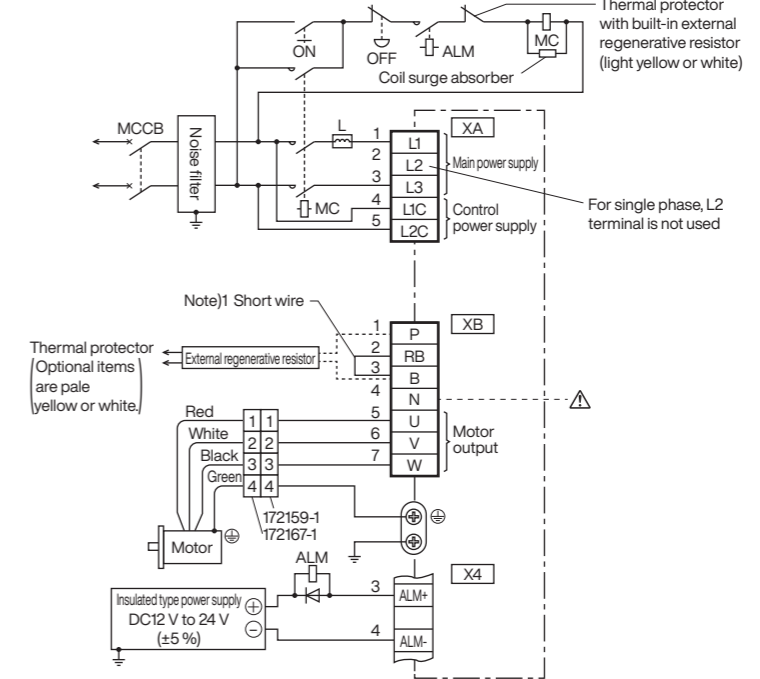

● Pin No. descriptions of X4 are based on shipping parameters.

*The motor brake power supply and connector X4 power supply must be insulated. Do not connect them to the same power source.

For A frame, B frame Three phase 200 V

●For lead wire type motor

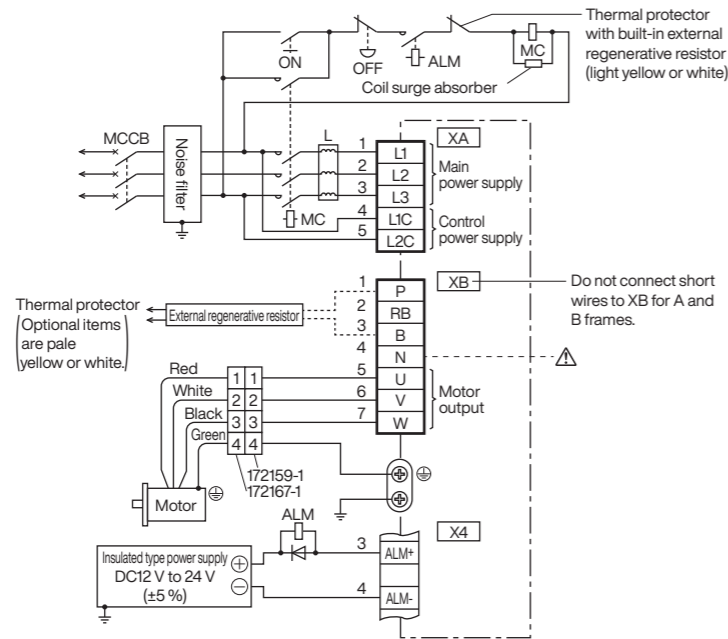

● Pin No. descriptions of X4 are based on shipping parameters.

*The motor brake power supply and connector X4 power supply must be insulated. Do not connect them to the same power source.

■Connection of the regenerative resistor

Frame type	Short line	Built-in regenerative resistor	Connector XB connection: ⚠ Do not connect anything to "N"	
			When using an external regenerative resistor	When an external regenerative resistor is not used
A frame B frame	None	None	Between P and B: Connect external regenerative resistor	Between P and B: Always open

*For the specifications of the motor side connector, please refer to the A7 Family catalog Options part.

For C frame, D frame Three phase 200 V

●For lead wire type motor

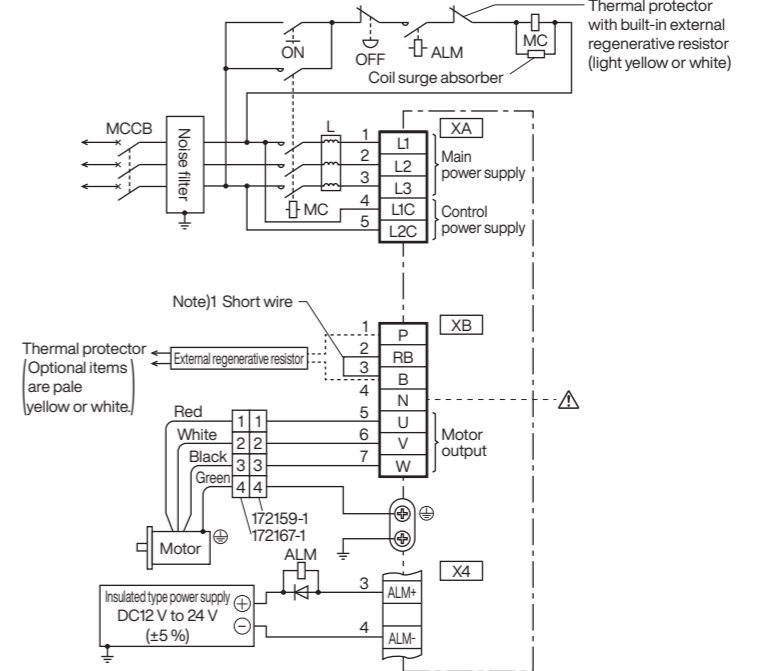

● Pin No. descriptions of X4 are based on shipping parameters.

*The motor brake power supply and connector X4 power supply must be insulated. Do not connect them to the same power source.

Note)1

Frame type	Short wire (Accessory)	Built-in regenerative resistor	Connector XB connection: ⚠ Do not connect anything to "N"	
			When using an external regenerative resistor	When an external regenerative resistor is not used
C frame D frame	Yes	Yes	Remove the attached short line between RB and B. Between P and B: Connect external regenerative resistor	Short circuit with attached short wire between RB and B

*For the specifications of the motor side connector, please refer to the A7 Family catalog Options part.

A safety circuit that controls safety functions is made by connecting the host controller. If you do not want to construct a safety circuit, please use the included safety bypass plug.

Safety Torque Off (STO) Function Overview

The Safe Torque Off (STO) function uses a safety input signal to forcibly turn off the drive signal of the power transistor inside the servo driver using a circuit (hardware) to cut off the motor current and output torque.

When the STO function is activated, the servo driver turns off the servo ready output signal (S-RDY) and enters the STO state, and "St" is displayed on the front panel. Also, when the STO input is released and the Servo-On input is turned off (OFF), the state automatically transitions to the Servo-Off state.

Safety precautions

- When using the STO function, be sure to perform a risk assessment on the device and confirm that the system satisfies the safety requirements. If the product is used in conditions that do not meet the safety requirements, it may lead to personal injury.
- Even when the STO function is working, the following dangers still exist, so be sure to consider safety in your risk assessment. Incorrect use may result in personal injury.
 - If there is an external force (such as gravity on a vertical axis), the motor will move. If holding is required, use a separate external brake or other means. Please note that the brake of a servo motor with a brake is only for holding and cannot be used for braking purposes.
 - Furthermore, even if there is no external force, if parameter Pr5.10 "Sequence at alarm" is set to free run (dynamic brake disabled), the motor will free run and the stopping distance will be longer. Please do not let this become a problem.
 - Due to a power transistor failure, etc., the motor may move within a range of up to 180 electrical degrees. Please do not let this become a problem.
 - The STO function cuts off power to the motor, but does not cut off power to the servo driver and does not provide electrical isolation. When performing maintenance on the servo driver, take other measures such as cutting off the power to the servo driver.
- EDM output signals are not safety outputs. Do not use it for any purpose other than the failure monitoring function. Incorrect use may result in personal injury.
- The STO status monitor output signal is not a safety-related part. When designing the system, make sure to avoid dangerous conditions even if the STO condition monitor output signal cannot be output normally. Incorrect use may result in personal injury.
- The dynamic brake and external brake release signal outputs are not safety-related parts. Make sure that the system design avoids dangerous conditions even if the external brake release fails during STO conditions. Incorrect use may result in personal injury.
- When using the STO function, connect equipment that complies with safety standards. Use of equipment that does not meet safety standards may result in personal injury.

[Pin arrangement]

(View from the cable side)

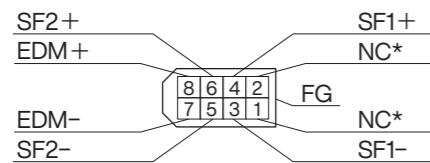

*Do not connect anything to the NC.

● System configuration example

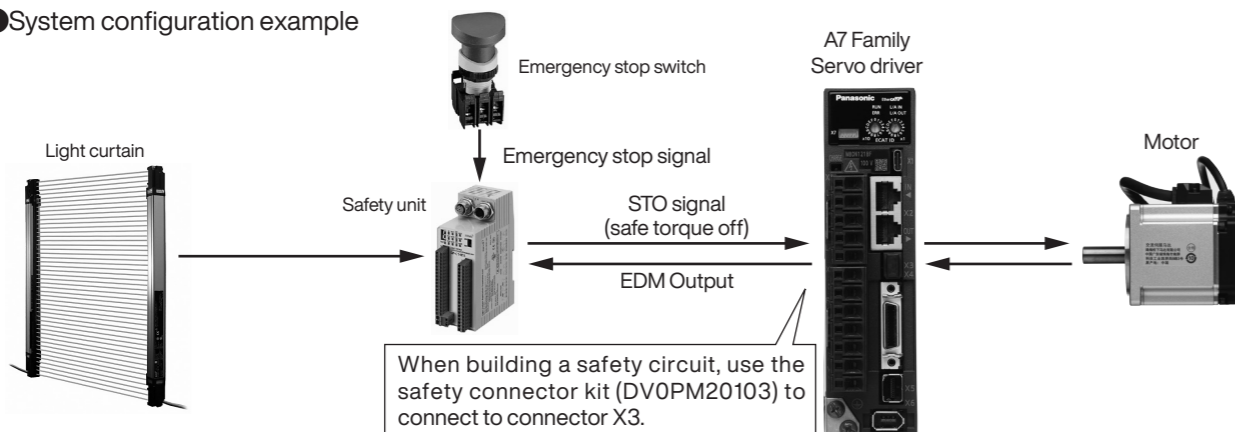

When building a safety circuit, use the safety connector kit (DV0PM20103) to connect to connector X3.

Connector X4 connection

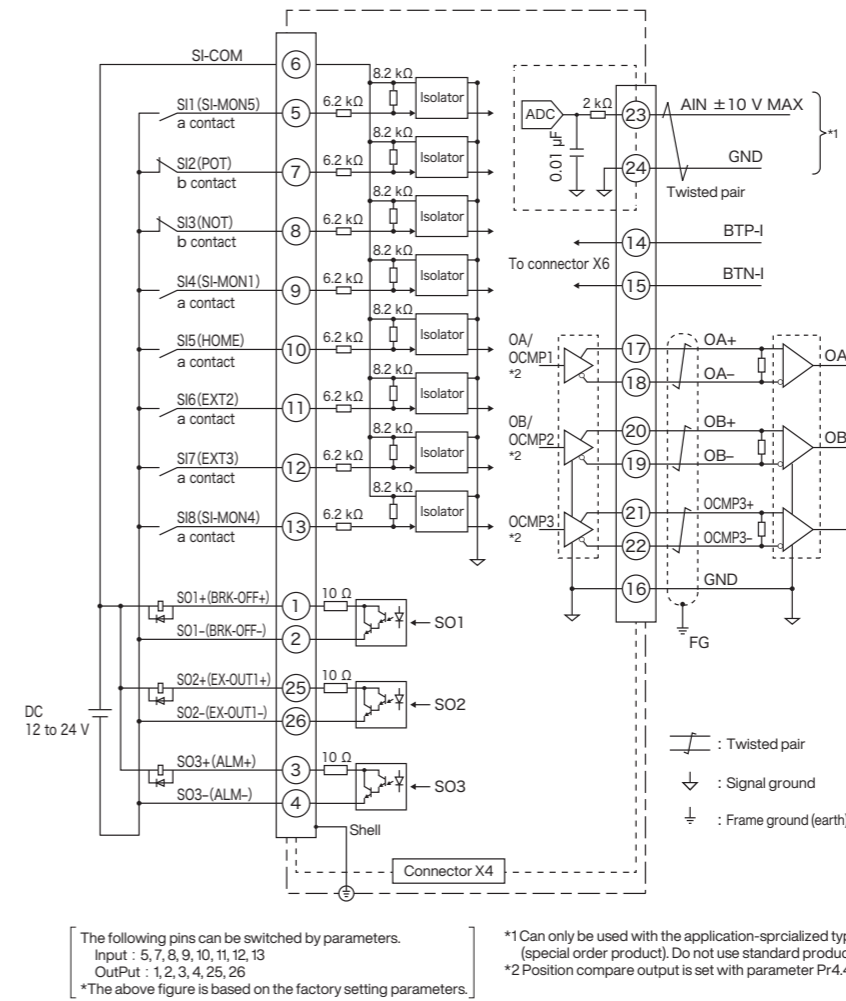

The following pins can be switched by parameters.
Input : 5, 7, 8, 9, 10, 11, 12, 13
Output : 1, 2, 3, 4, 25, 26
*The above figure is based on the factory setting parameters.

*1 Can only be used with the application-specialized type (special order product). Do not use standard products.
*2 Position compare output is set with parameter Pr4.47.

<Note> For connection connectors, please refer to the A7 family catalog Options part. The circuit diagram above shows the pin functions (factory settings) of the RTEX compatible servo driver (A7N). Please refer to the table on the right for the pin functions (factory settings) of the EtherCAT compatible servo driver (A7B).

● Pin function factory setting

Pin number	Pin function	Servo driver with RTEX (A7N)		Servo driver with EtherCAT (A7B)	
		Signal	Pin function	Signal	Pin function
6	SI-COM	General purpose input common	SI-COM	General purpose input common	
5	SI-MON5	General monitor Input 5	SI-MON5	General monitor Input 5	
7	POT	Qazzqazz-0	POT	Qazzqazz-0	
8	NOT	Negative direction over travel inhibit input	NOT	Negative direction over travel inhibit input	
9	SI-MON1	General monitor Input 1	HOME	Near origin input	
10	HOME	Near origin input	EXT1	External latch input 1	
11	EXT2	External latch input 2	EXT2	External latch input 2	
12	EXT3	External latch input 3	SI-MON3	General monitor Input 3	
13	SI-MON4	General monitor Input 4	SI-MON4	General monitor Input 4	
1	BRK-OFF+	External brake release signal	BRK-OFF+	External brake release signal	
2	BRK-OFF-	External brake release signal	BRK-OFF-	External brake release signal	
25	EX-OUT+	General output 1	EX-OUT+	General output 1	
26	EX-OUT-		EX-OUT-		
3	ALM+	Servo alarm output	ALM+	Servo alarm output	
4	ALM-	Servo alarm output	ALM-		
23*1	AIN	±10 V max Analog input	AIN	±10 V max Analog input	
24*1	GND	Ground	GND	Ground	
14	BTP-I	Battery input for absolute encoder	BTP-I	Battery input for absolute encoder	
15	BTN-I	Battery input for absolute encoder	BTN-I	Battery input for absolute encoder	
17	OA+	A-phase output	OA+	A-phase output	
18	OA-	A-phase output	OA-	A-phase output	
20	OB+	B-phase output	OB+	B-phase output	
19	OB-	B-phase output	OB-		
21	—	—	—	—	
22	—	—	—	—	
16	GND	Ground	GND	Ground	

The factory settings for pins 9, 10, and 12 are different between the RTEX compatible driver (A7N) and the EtherCAT compatible driver (A7B).

Connector X5 connection

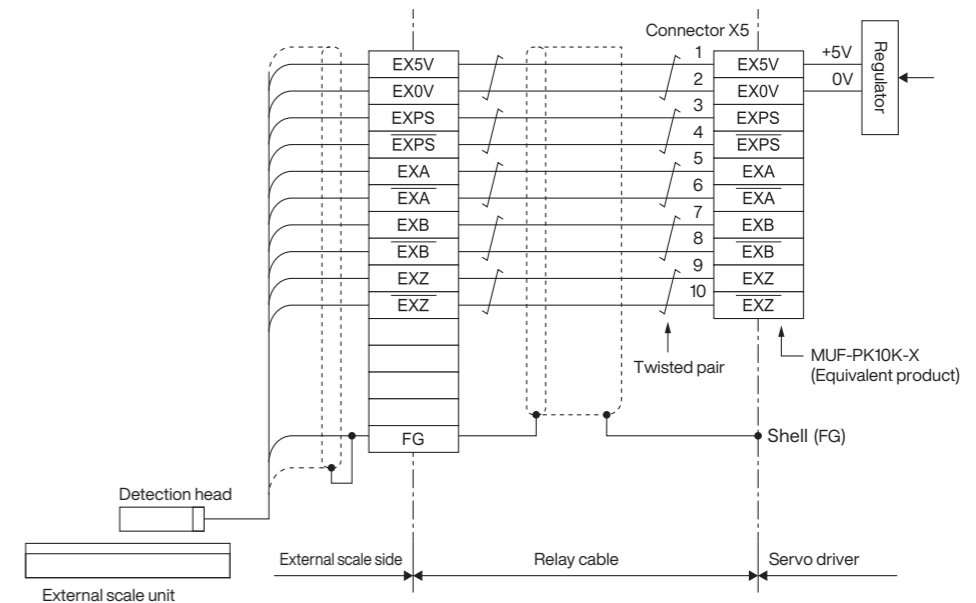

When using a 27 bit absolute encoder as absolute system*

*When using multi-turn data

80 mm sq. or less ●MHMG 50 W to 1000 W

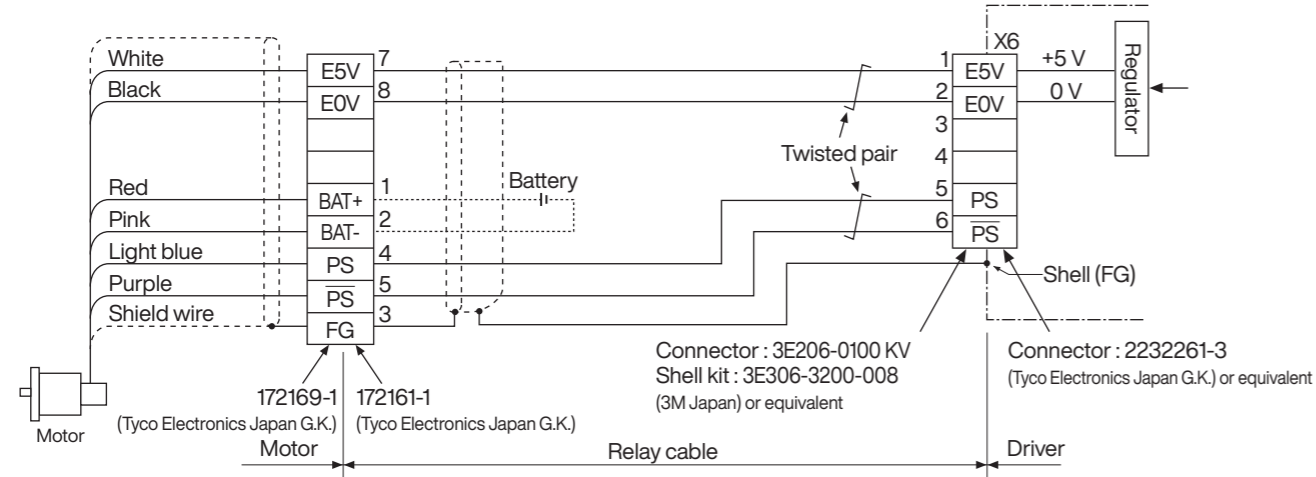

When using a 27 bit absolute encoder as an incremental system*

*Without Multi-turn data

80 mm sq. or less ●MHMG 50 W to 1000 W

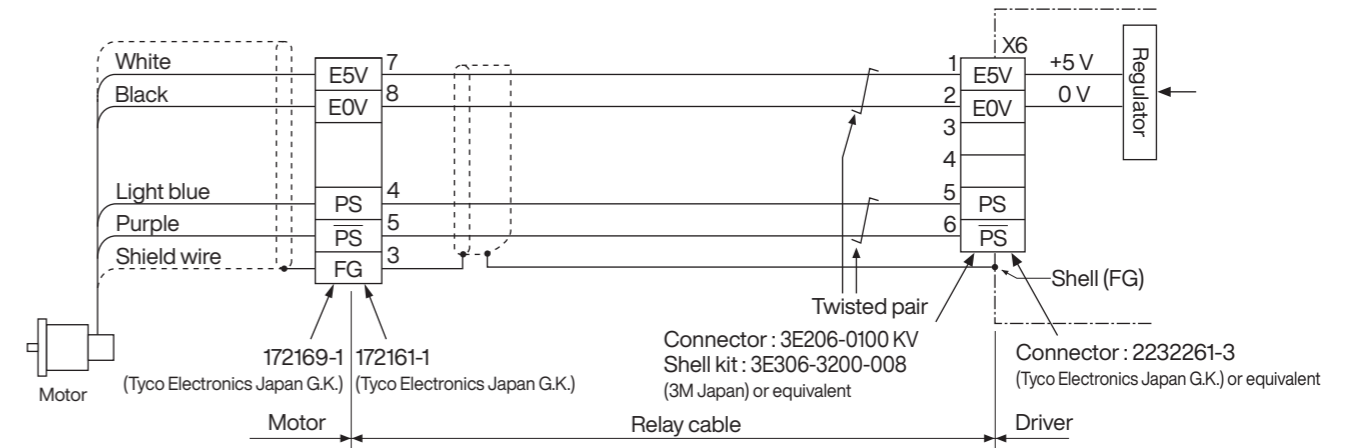

100 mm sq. or more ●MSMG 1.0 kW, 1.5 kW ●MHMG 1.0 kW, 1.5 kW
●MDMG 1.0 kW, 1.5 kW ●MGMG 0.85 kW, 1.3 kW

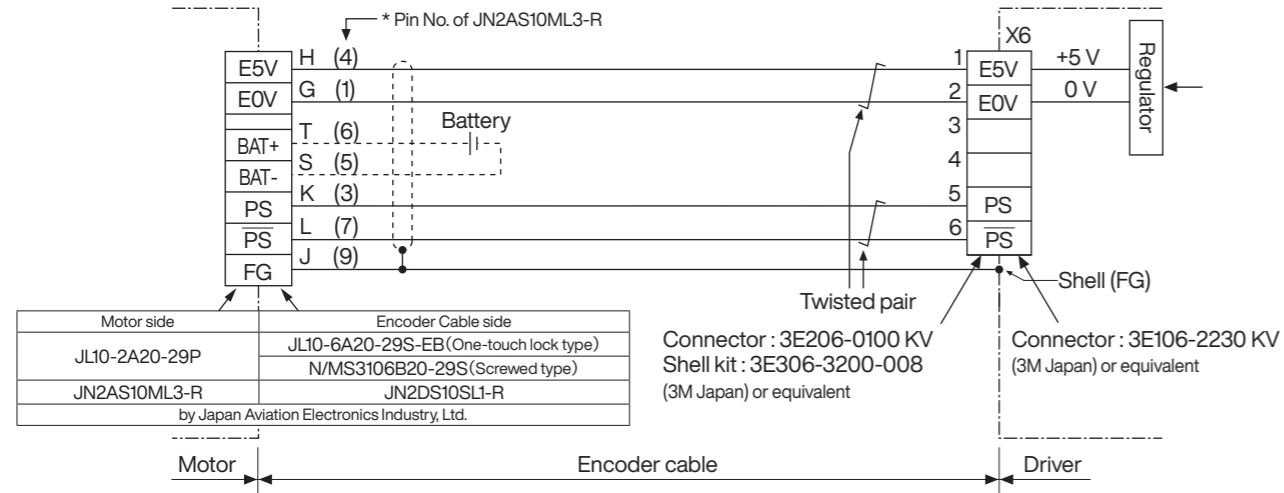

100 mm sq. or more ●MSMG 1.0 kW, 1.5 kW ●MHMG 1.0 kW, 1.5 kW
●MDMG 1.0 kW, 1.5 kW ●MGMG 0.85 kW, 1.3 kW

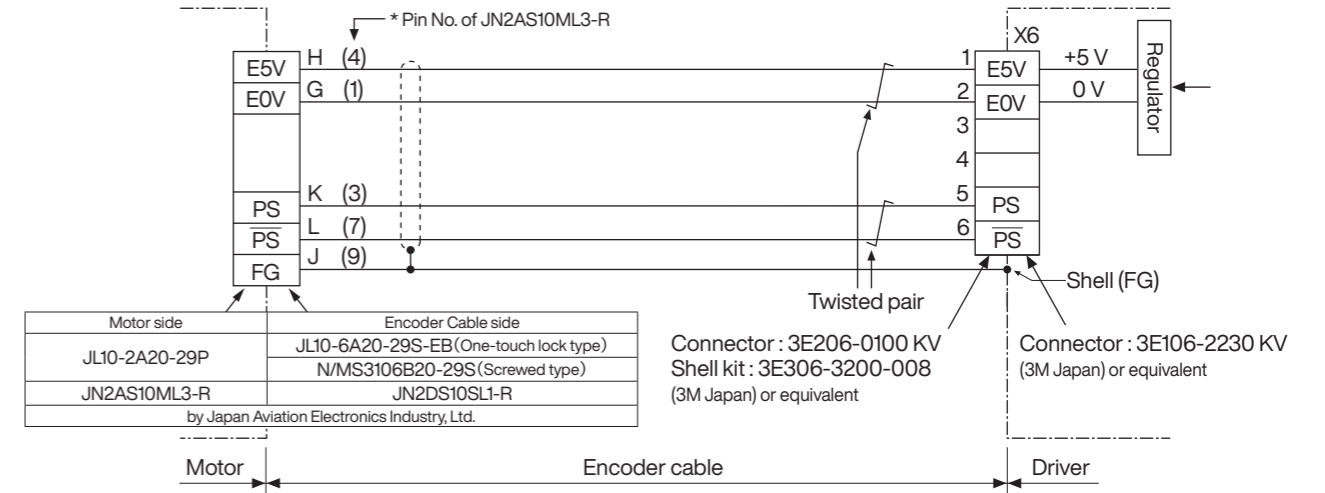

[Connector pin assignment] Please refer to the MINAS A7 Catalog "Option Part", page 2 "Motor connector specifications".

[Connector pin assignment] Please refer to the MINAS A7 Catalog "Option Part", page 2 "Motor connector specifications".

Driver external dimensions

*All descriptions are for the A7B series, but the external dimensions of the A7N series are the same. Refer to page 10 for more details.

*Specifications are subject to change due to improvements, etc. Please be sure to obtain the latest information when using this product. *Dimensions are subject to change, so if you are using it for design purposes, please inquire for confirmed dimensions. Before using the product, be sure to read the "Instruction Manual" and carefully check the precautions to ensure proper use.

A frame

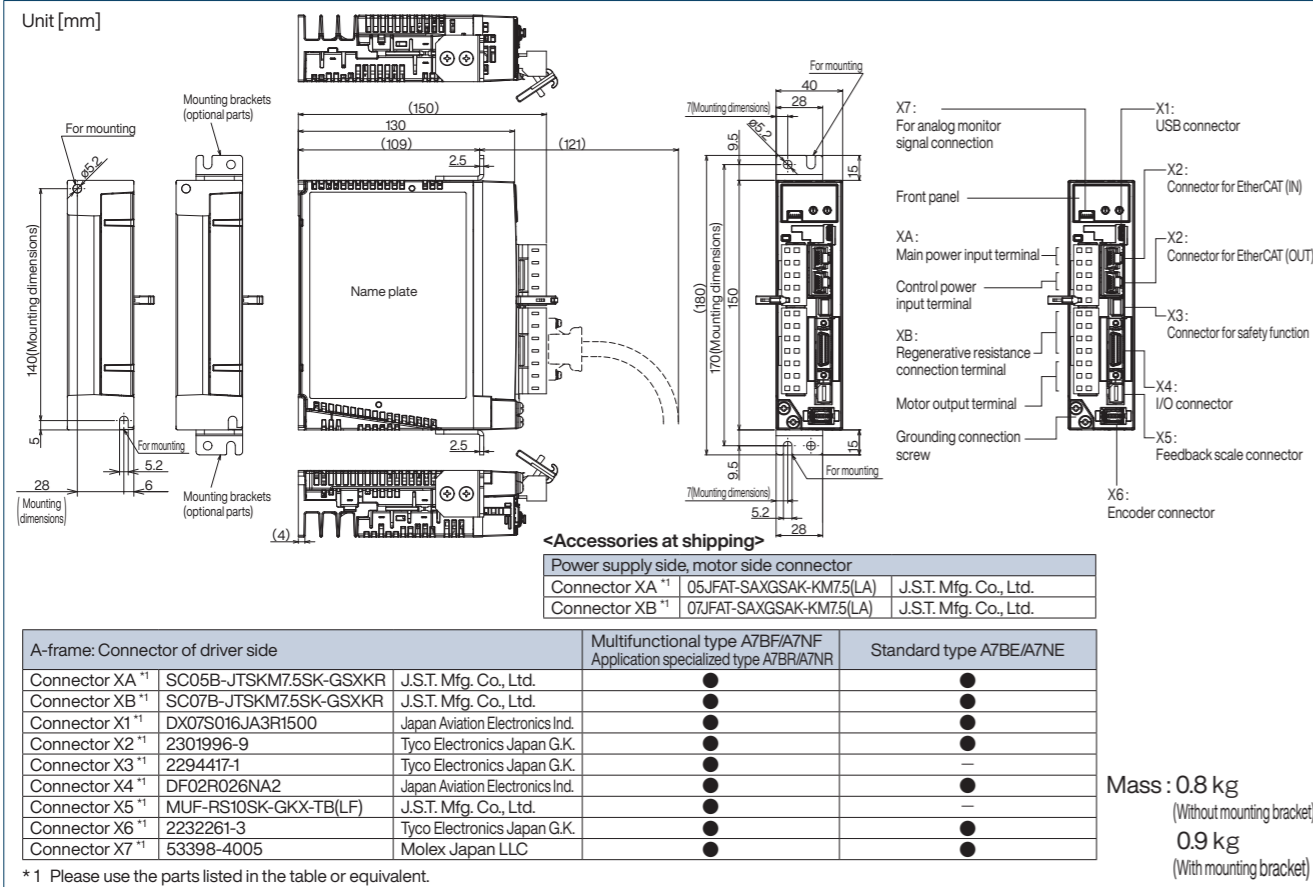

C frame

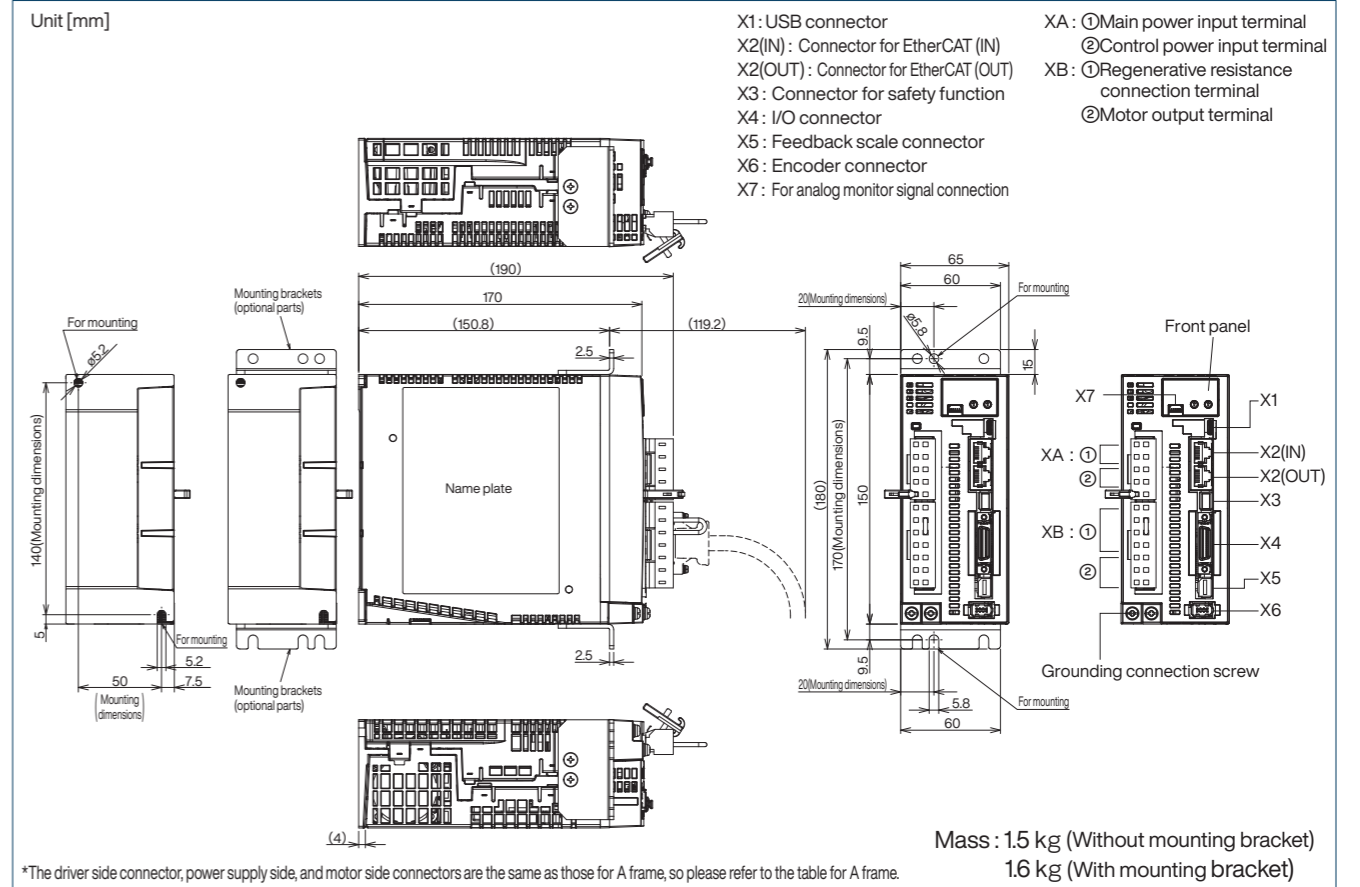

B frame

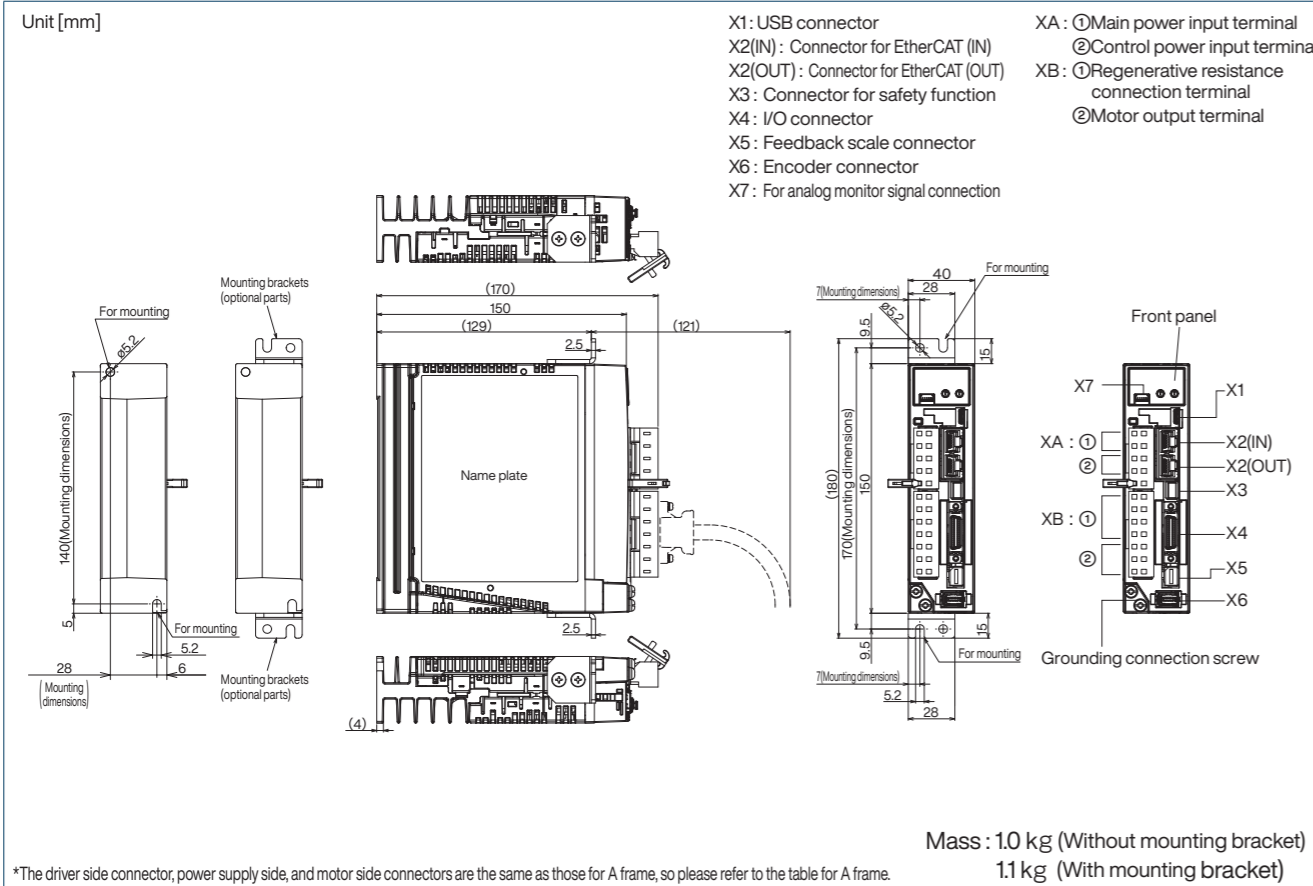

D frame (200 V)

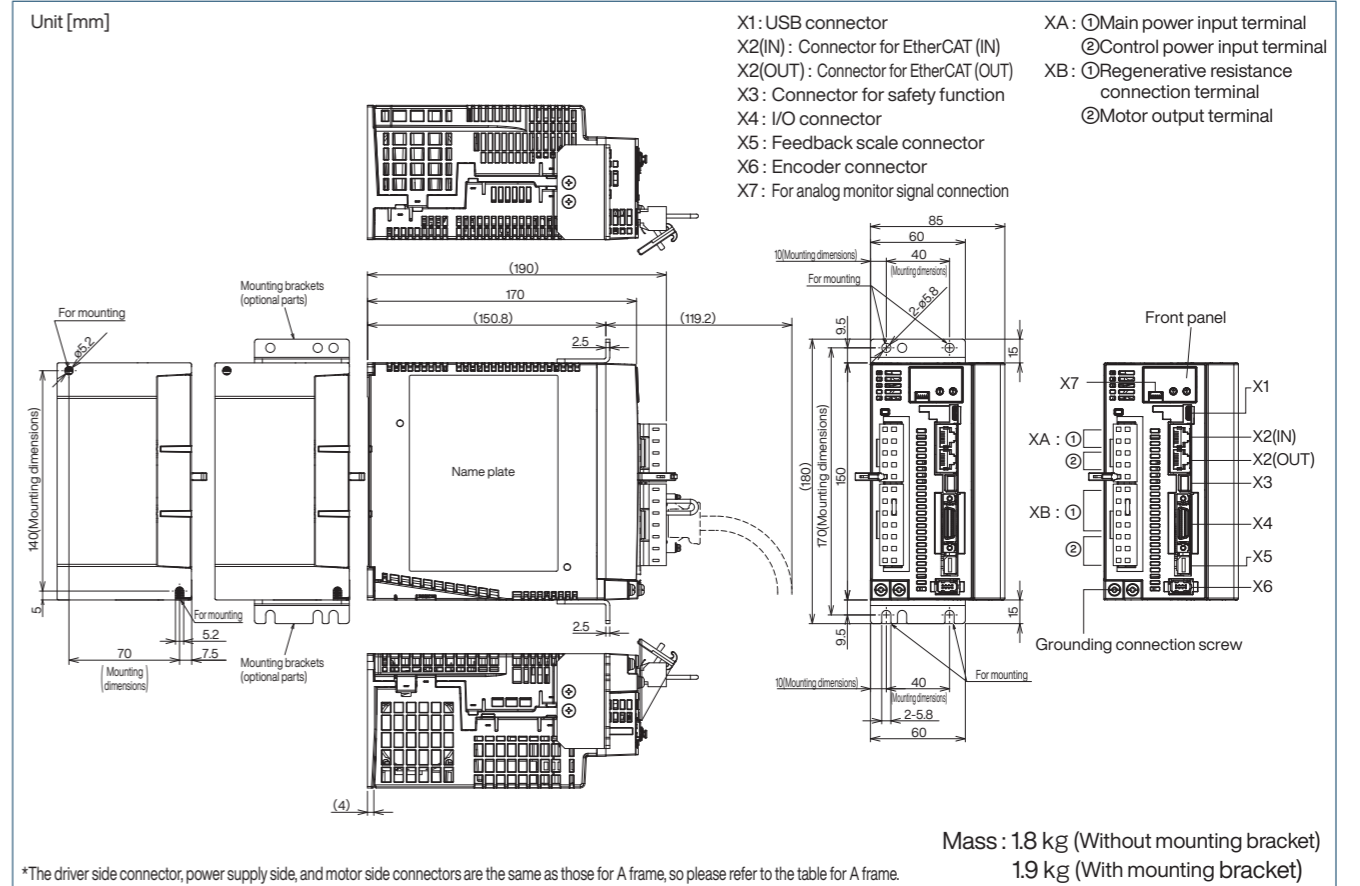

Specifications

Output		50 W		100 W		
Voltage specification		100 V	200 V	100 V	200 V	
Motor part number *1		MHMG5AZU1 □ 2		MHMG011U1 □ 2	MHMG012U1 □ 2	
Applicable driver	Part *2 number	A7B	MADN061B ■■	MADN065B ■■	MADN081B ■■	MADN065B ■■
		A7N	MADN061N ■■	MADN065N ■■	MADN081N ■■	MADN065N ■■
Outer frame symbol		A frame				
Power supply capacity (kVA)		0.4	0.5	0.4	0.5	
Rated torque (N·m)		0.16		0.32		
Continuous Stall Torque (N·m)		0.18		0.33		
Instantaneous maximum torque (N·m)		0.56		1.11		
Rated current [Reference value] (A(rms))		1.1		1.6	1.1	
Instantaneous maximum current [Reference value] (A(0-p))		5.5		8.0	5.5	
Regenerative braking frequency (times/min) Note)1, Note)2	No option	Unlimited				
	When using option	Unlimited (DV0P4280)	Unlimited (DV0P4281)	Unlimited (DV0P4280)	Unlimited (DV0P4281)	
Rated rotation speed (r/min)		3000				
Maximum rotation speed (r/min)		7150				
Rotor inertia ($\times 10^{-4}$ kg·m ²)	No brake	0.0366		0.0648		
	With brake	0.0401		0.0674		
Recommended inertia ratio Note)3		30 times or less				
Rotary encoder specification *3		27-bit Absolute *3				
	Resolution per revolution	134217728				
Torque characteristic		A		B	C	

● Brake specifications (Please refer to page 39 for details.)

(It is released when the holding brake is energized. Cannot be used for braking while the motor is rotating.)

Static friction torque (N·m)	0.38 or more
Suction time (ms)	35 or less
Release time Note)4 (ms)	20 or less
Excitation current DC (A)	0.3
Release voltage DC (V)	1 or more
Excitation voltage DC (V)	24 ± 2.4

● Allowable load (Please refer to page 39 for details.)

No operation	Allowable radial load (N)	147
	Allowable thrust load A direction (N)	88
	Allowable thrust load B direction (N)	117
In operation	Allowable radial load (N)	68
	Allowable thrust load (N)	58

● See page 38 for notes 1) to 4).

● Refer to pages 22 to 23 for the external dimension of driver.

*1 The □ in the motor model number represents the structure of the motor. Please refer to page 8 for details.

*2 Please refer to page 8 for details about ■■ in the driver part number.

*3 When using as an incremental system (not using multi-turn data), do not connect the battery for the absolute encoder.

● Torque characteristic

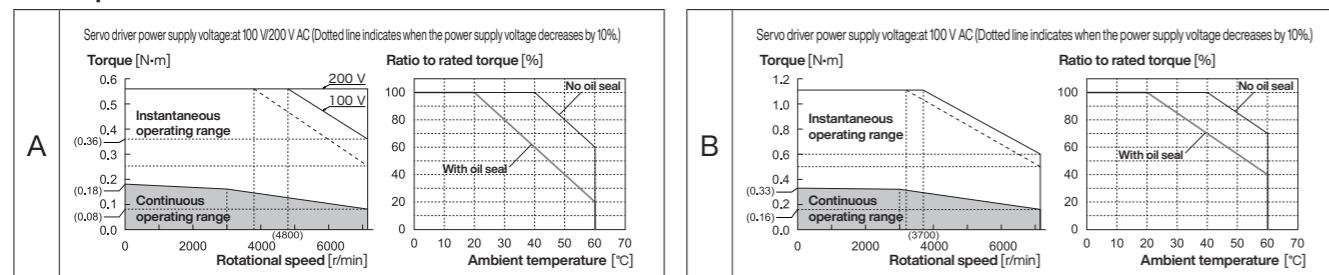

* Specifications are subject to change due to improvements, etc. Please be sure to obtain the latest information when using this product.

The external dimensions

The external dimensions are shown with a brake.

Unit [mm]

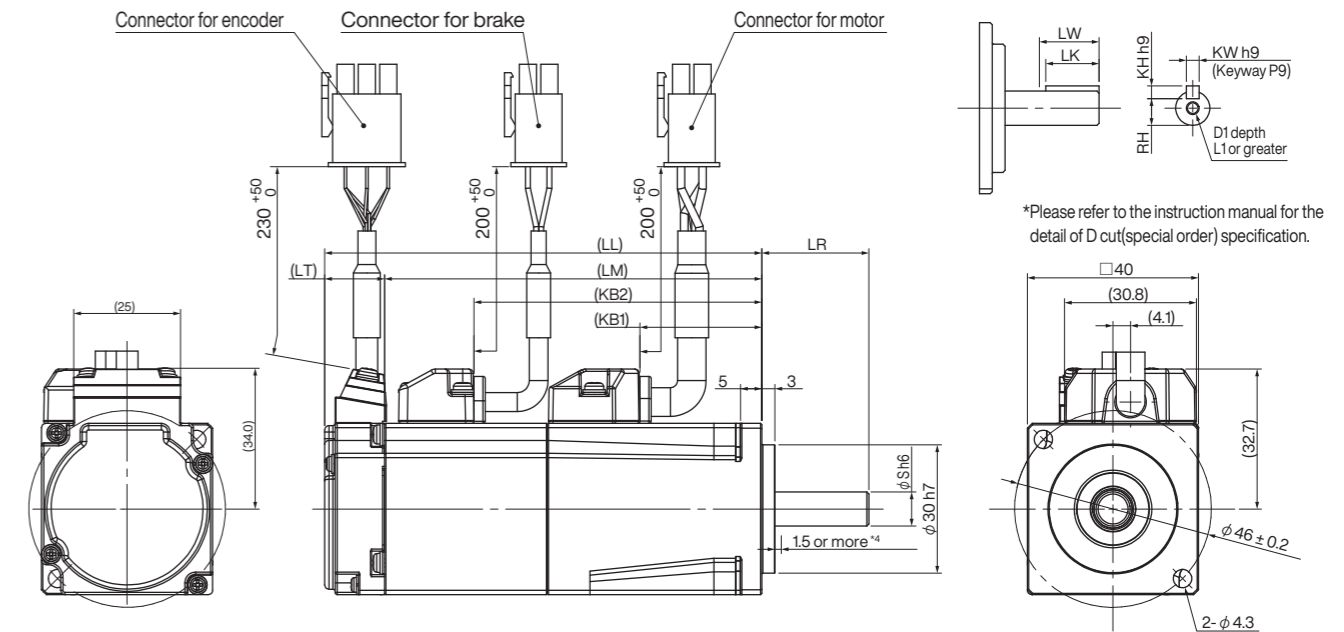

*Please refer to the instruction manual for the detail of D cut (special order) specification.

*4 Insertion position of boss (with oil seal only)

Dimension table

Unit [mm]

Motor part number *5	Output (W)	LL				LR	LM				S	LT	KB1	
		No brake		With brake			No brake		With brake				With/without brakes	
		No oil seal	With oil seal	No oil seal	With oil seal		No oil seal	With oil seal	No oil seal	With oil seal				
MHMG5AZU1 □ 2	50	53.8		90		25	39.8		76		8	14	16.3	
MHMG01 △ U1 □ 2	100	66		102.2			52		88.2				28.5	

Motor part number *5	Output (W)	KB2		LW	LK	KW	KH	RH	D1	L1	Mass (kg)			
		With brake									No brake		With brake	
		No oil seal	With oil seal								No oil seal	With oil seal	No oil seal	With oil seal
MHMG5AZU1 □ 2	50	55.1		14	12.5	3	3	6.2	M3	6	0.29	0.30	0.51	0.52
MHMG01 △ U1 □ 2	100	67.3									0.37	0.38	0.60	0.61

*5 The △ in the motor part number represents the motor voltage specification, and the □ represents the motor structure. Please refer to page 8 for details.

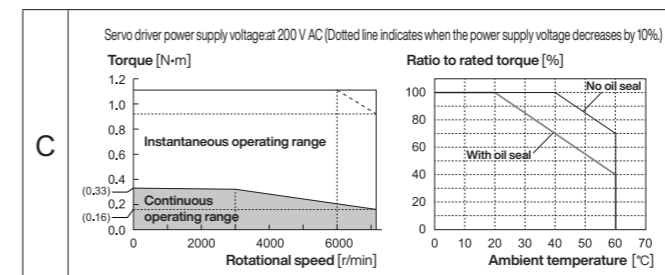

Note: If high-speed response is required, lower the load inertia ratio to rotor inertia moment.

Dimensions are subject to change, so if you are using it for design purposes, please inquire for final dimensions.

Before using the product, be sure to read the "Instruction Manual" and carefully check the precautions to ensure proper use.

Specifications

Output		200 W		400 W		
Voltage specification		100 V	200 V	100 V	200 V	
Motor part number *1		MHMG021U1 □ 2	MHMG022U1 □ 2	MHMG041U1 □ 2	MHMG042U1 □ 2	
Applicable driver	Part *2 number	A7B	MBDN121B ■■	MADN085B ■■	MCDN201B ■■	MBDN125B ■■
		A7N	MBDN121N ■■	MADN085N ■■	MCDN201N ■■	MBDN125N ■■
Outer frame symbol		B frame	A frame	C frame	B frame	
Power supply capacity (kVA)		0.5	0.6	0.9	1.0	
Rated torque (N·m)		0.64		1.27		
Continuous Stall Torque (N·m)		0.76		1.40		
Instantaneous maximum torque (N·m)		2.23		4.46		
Rated current [Reference value] (A(rms))		2.2	1.4	4.1	2.2	
Instantaneous maximum current [Reference value] (A(0-p))		11	6.9	20	11	
Regenerative braking frequency (times/min) Note)1, Note)2	No option	Unlimited				
	When using option	Unlimited (DVOP4283)		Unlimited (DVOP4282)		
Rated rotation speed (r/min)		3000				
Maximum rotation speed (r/min)		6700	7150	6700		
Rotor inertia ($\times 10^{-4}$ kg·m ²)	No brake	0.254		0.462		
	With brake	0.271		0.479		
Recommended inertia ratio Note)3		30 times or less				
Rotary encoder specification *3		27-bit Absolute *3				
Resolution per revolution		134217728				
Torque characteristic		A	B	C	D	

● Brake specifications (Please refer to page 39 for details.)

(It is released when the holding brake is energized. Cannot be used for braking while the motor is rotating.)

Static friction torque (N·m)	1.6 or more
Suction time (ms)	50 or less
Release time Note)4 (ms)	20 or less
Excitation current DC (A)	0.36
Release voltage DC (V)	1 or more
Excitation voltage DC (V)	24 ± 2.4

● Allowable load (Please refer to page 39 for details.)

No operation	Allowable radial load (N)	392
	Allowable thrust load A direction (N)	147
	Allowable thrust load B direction (N)	196
In operation	Allowable radial load (N)	245
	Allowable thrust load (N)	98

● See page 38 for notes 1) to 4).

● Refer to pages 22 to 23 for the external dimension of driver.

*1 The □ in the motor model number represents the structure of the motor. Please refer to page 8 for details.

*2 Please refer to page 8 for details about ■■ in the driver part number.

*3 When using as an incremental system (not using multi-turn data), do not connect the battery for the absolute encoder.

● Torque characteristic

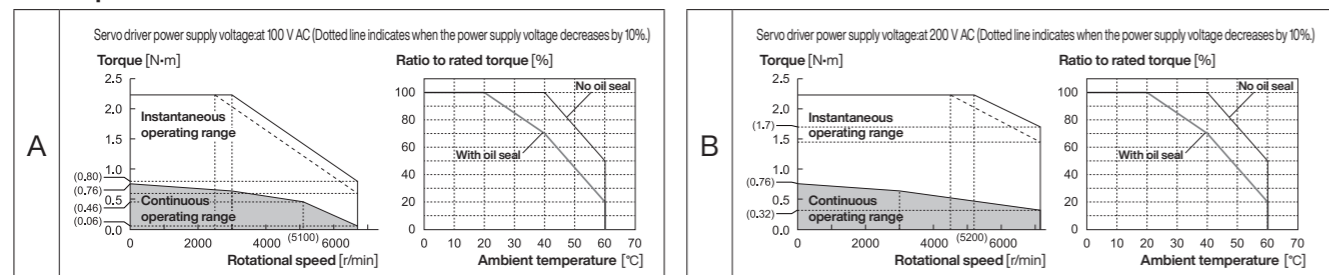

* Specifications are subject to change due to improvements, etc. Please be sure to obtain the latest information when using this product.

The external dimensions

The external dimensions are shown with a brake.

Unit [mm]

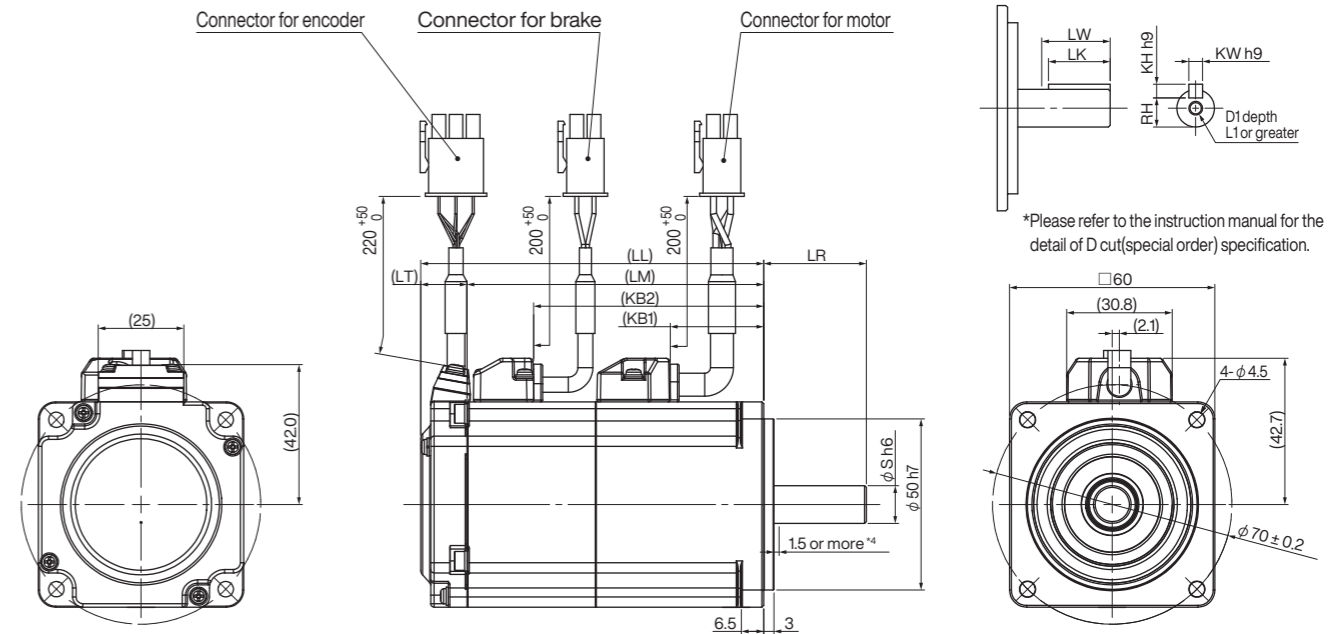

*4 Insertion position of boss (with oil seal only)

Dimension table

Unit [mm]

Motor part number *5	Output (W)	LL				LR	LM				S	LT	KB1	
		No brake		With brake			No brake		With brake				With/without brakes	
		No oil seal	With oil seal	No oil seal	With oil seal		No oil seal	With oil seal	No oil seal	With oil seal				
MHMG02 Δ U1 □ 2	200	65.5		100.2		30	52		86.7		11	13.5	27.3	
MHMG04 Δ U1 □ 2	400	82		116.7			68.5		103.2				14	

Motor part number *5	Output (W)	KB2		LW	LK	KW	KH	RH	D1	L1	Mass (kg)			
		With brake									No brake		With brake	
		No oil seal	With oil seal								No oil seal	With oil seal	No oil seal	With oil seal
MHMG02 Δ U1 □ 2	200	67.2		20	18	4	4	8.5	M4	8	0.73	0.74	1.2	
MHMG04 Δ U1 □ 2	400	83.7		25	22.5	5	5	11	M5	10	1.0	1.5		

*5 The Δ in the motor part number represents the motor voltage specification, and the □ represents the motor structure. Please refer to page 8 for details.

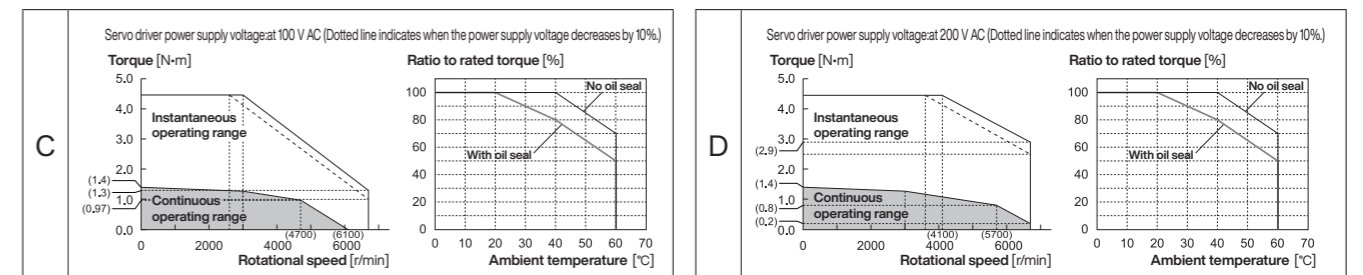

Note: If high-speed response is required, lower the load inertia ratio to rotor inertia moment.

Dimensions are subject to change, so if you are using it for design purposes, please inquire for final dimensions.

Before using the product, be sure to read the "Instruction Manual" and carefully check the precautions to ensure proper use.

Specifications

Output		750 W	1000 W
Voltage specification		200 V	
Motor part number *1		MHMG082U1 □ 2	MHMG092U1 □ 2
Applicable driver	Part *2 number	A7B MCDN205B ■■	A7N MDDN405B ■■
	Outer frame symbol	C frame	D frame
		MCDN205N ■■	MDDN405N ■■
Power supply capacity (kVA)	1.9	2.4	
Rated torque (N·m)	2.39	3.18	
Continuous Stall Torque (N·m)	2.86	3.34	
Instantaneous maximum torque (N·m)	8.36	11.1	
Rated current [Reference value] (A(rms))	3.8	5.7	
Instantaneous maximum current [Reference value] (A(0-p))	20	30	
Regenerative braking frequency (times/min) Note)1, Note)2	No option	Unlimited	
	When using option	Unlimited (DVOP4283)	Unlimited (DVOP4284)
Rated rotation speed (r/min)	3000		
Maximum rotation speed (r/min)	6000	6700	
Rotor inertia ($\times 10^{-4}$ kg·m ²)	No brake	1.30	1.72
	With brake	1.38	1.80
Recommended inertia ratio Note)3	20 times or less		15 times or less
Rotary encoder specification *3	27-bit Absolute *3		
	Resolution per revolution	134217728	
Torque characteristic	A	B	

● Brake specifications (Please refer to page 39 for details.)

(It is released when the holding brake is energized. Cannot be used for braking while the motor is rotating.)

Static friction torque (N·m)	3.8 or more
Suction time (ms)	70 or less
Release time Note)4 (ms)	20 or less
Excitation current DC (A)	0.42
Release voltage DC (V)	1 or more
Excitation voltage DC (V)	24 ± 2.4

● Allowable load (Please refer to page 39 for details.)

No operation	Allowable radial load (N)	686
	Allowable thrust load A direction (N)	294
	Allowable thrust load B direction (N)	392
In operation	Allowable radial load (N)	392
	Allowable thrust load (N)	147

● See page 38 for notes 1) to 4).

● Refer to pages 22 to 23 for the external dimension of driver.

*1 The □ in the motor model number represents the structure of the motor. Please refer to page 8 for details.

*2 Please refer to page 8 for details about ■■ in the driver part number.

*3 When using as an incremental system (not using multi-turn data), do not connect the battery for the absolute encoder.

● Torque characteristic

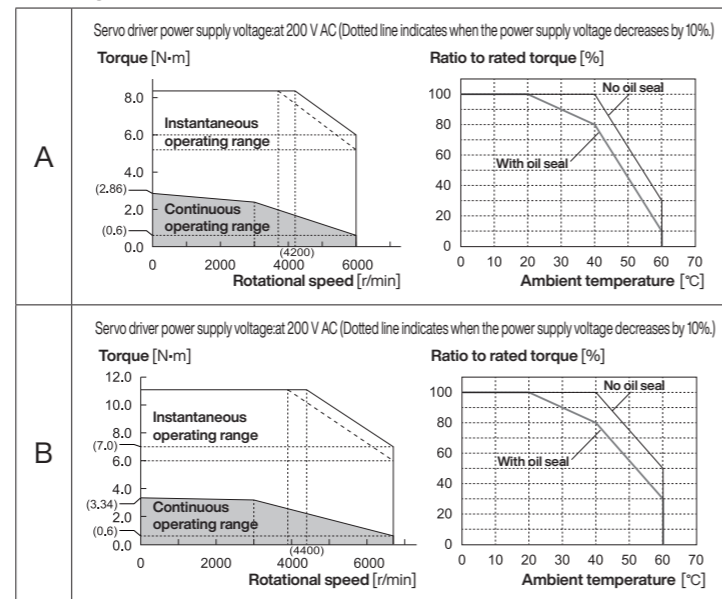

* Specifications are subject to change due to improvements, etc. Please be sure to obtain the latest information when using this product.

The external dimensions

The external dimensions are shown with a brake.

Unit [mm]

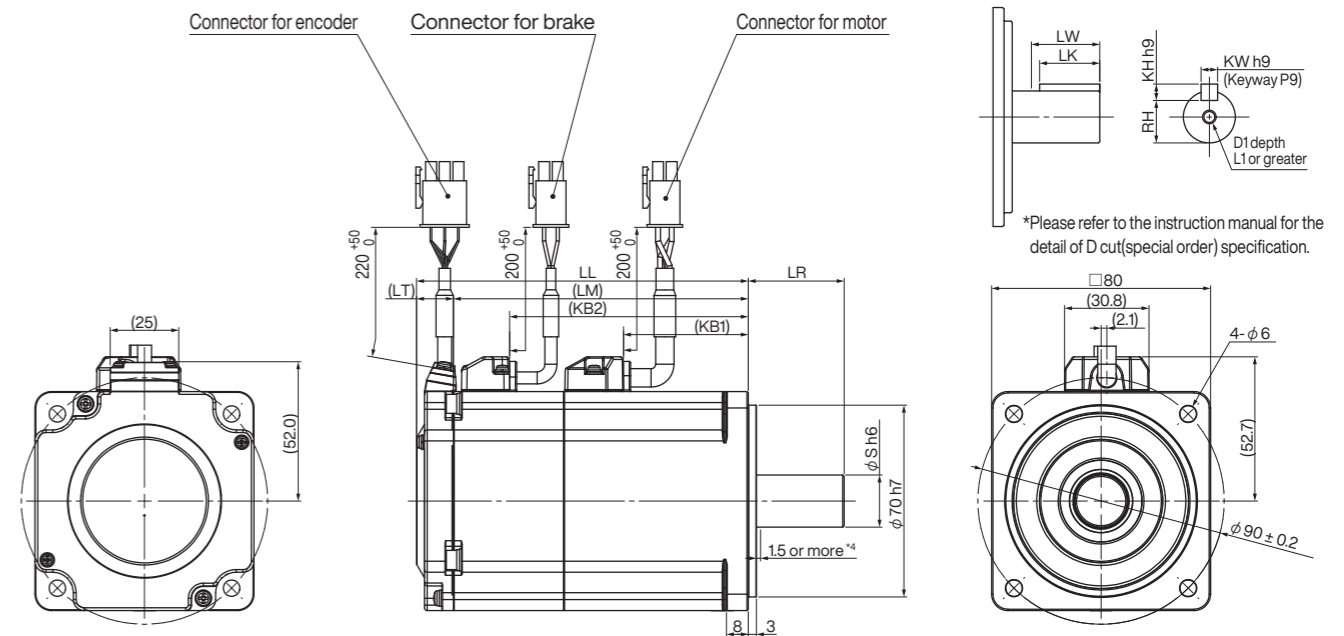

*Please refer to the instruction manual for the detail of D cut (special order) specification.

*4 Insertion position of boss (with oil seal only)

Dimension table

Motor part number *5	Output (W)	LL		LR	LM				S	LT	KB1	
		No brake			With brake		With/without brakes					
		No oil seal	With oil seal		No oil seal	With oil seal	No oil seal	With oil seal				
MHMG082U1 □ 2	750	86	121.2	35	72.5	107.7	19	13.5	45.6			
MHMG092U1 □ 2	1000	97.2	132.4	35	83.7	118.9	19	13.5	56.8			

Motor part number *5	Output (W)	KB2		LW	LK	KW	KH	RH	D1	L1	Mass (kg)			
		With brake									No brake		With brake	
		No oil seal	With oil seal								No oil seal	With oil seal	No oil seal	With oil seal
MHMG082U1 □ 2	750	87.2		25	22	6	6	15.5	M5	10	1.9		2.7	
MHMG092U1 □ 2	1000	98.4		25	22	6	6	15.5	M5	10	2.3		3.1	

*5 The □ represents the motor structure. Please refer to page 8 for details.

Note: If high-speed response is required, lower the load inertia ratio to rotor inertia moment.

Dimensions are subject to change, so if you are using it for design purposes, please inquire for final dimensions.

Before using the product, be sure to read the "Instruction Manual" and carefully check the precautions to ensure proper use.

Specifications

Output		1.0 kW	1.5 kW
Voltage specification		200 V	200 V
Motor part number *1		MHMG102U1 □□	MHMG152U1 □□
Applicable driver	Part *2 number	A7B MCDN245B ■■	A7N MCDN245N ■■
	Outer frame symbol	C frame	D frame
Power supply capacity (kVA)		2.4	2.9
Rated torque (N·m)		4.77	7.16
Continuous Stall Torque (N·m)		5.25	7.52
Instantaneous maximum torque (N·m)		14.3	21.5
Rated current [Reference value] (A(rms))		5.2	8.0
Instantaneous maximum current [Reference value] (A(0-p))		22	34
Regenerative braking frequency (times/min) Note)1, Note)2	No option	Unlimited	
	When using option	Unlimited (DV0P4284)	
Rated rotation speed (r/min)		2000	
Maximum rotation speed (r/min)		3000	
Rotor inertia (×10 ⁻⁴ kg·m ²)	No brake	22.9	33.4
	With brake	24.1	34.6
Recommended inertia ratio Note)3		5 times or less	
Rotary encoder specification *3		27-bit Absolute *3	
	Resolution per revolution	134217728	
Torque characteristic		A	B

● Brake specifications (Please refer to page 39 for details.)

(It is released when the holding brake is energized.)
(Cannot be used for braking while the motor is rotating.)

Static friction torque (N·m)	13.7 or more
Suction time (ms)	100 or less
Release time Note)4 (ms)	50 or less
Excitation current DC (A)	0.79
Release voltage DC (V)	2 or more
Excitation voltage DC (V)	24 ± 2.4

● Allowable load (Please refer to page 39 for details.)

No operation	Allowable radial load (N)	980
	Allowable thrust load A direction (N)	588
	Allowable thrust load B direction (N)	686
In operation	Allowable radial load (N)	490
	Allowable thrust load (N)	196

● See page 38 for notes 1) to 4).

● Refer to pages 22 to 23 for the external dimension of driver.

*1 The □ in the motor model number represents the structure of the motor. Please refer to page 8 for details.

*2 Please refer to page 8 for details about ■■ in the driver part number.

*3 When using as an incremental system (not using multi-turn data), do not connect the battery for the absolute encoder.

● Torque characteristic

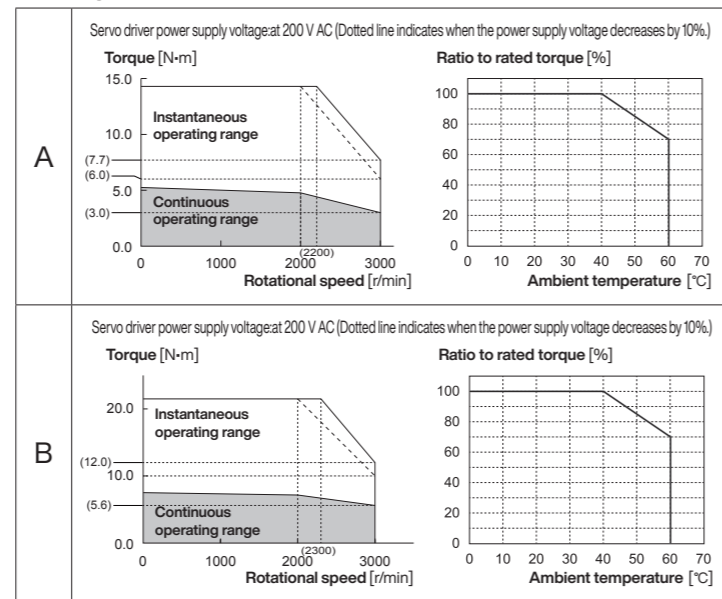

* Specifications are subject to change due to improvements, etc. Please be sure to obtain the latest information when using this product.

The external dimensions

* The encoder connector shape of JN2 (small type) is listed.

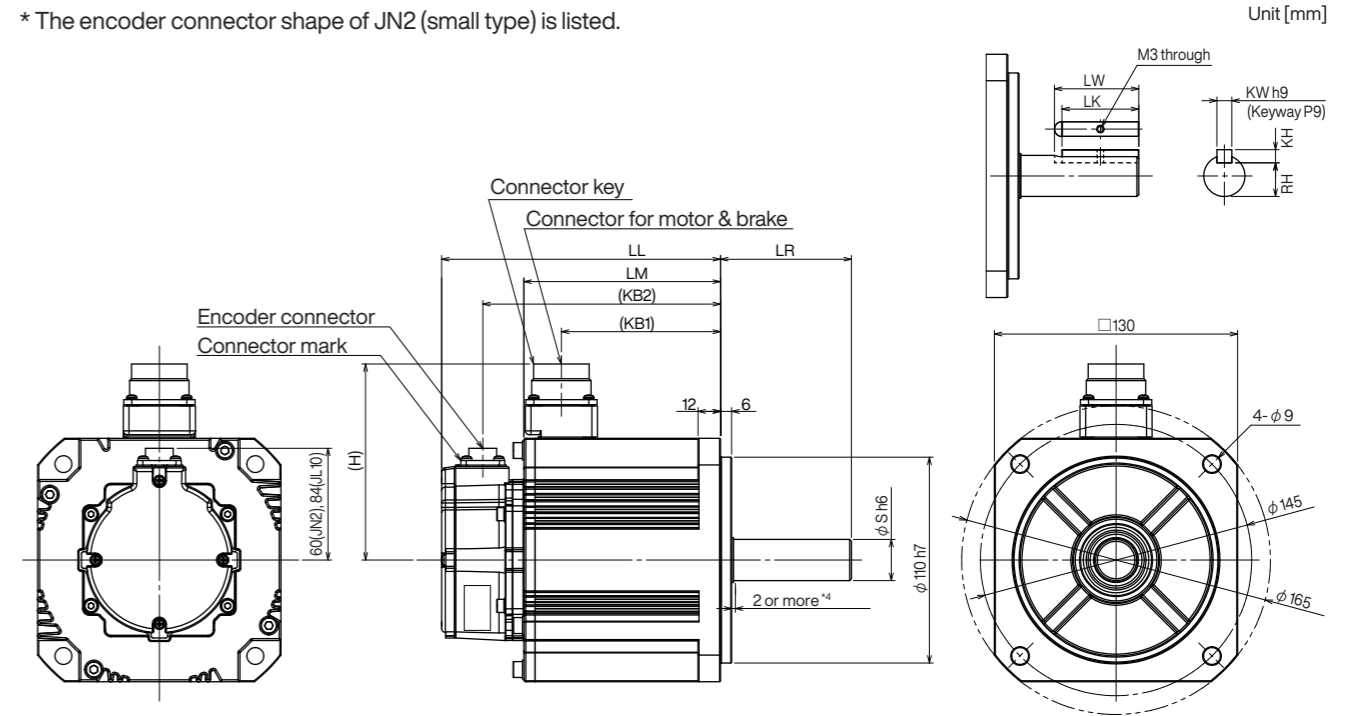

*4 Insertion position of boss

Dimension table

Motor part number *5	Output (kW)	LL				LR	LM		S	KB1	
		No brake		With brake			No brake	With brake		No brake	With brake
		Encoder connector JN2	Encoder connector JL10	Encoder connector JN2	Encoder connector JL10		With oil seal			With oil seal	
MHMG102U1 □□	1.0	149	150	177	178	70	105	133	22	85	71
MHMG152U1 □□	1.5	163	164	191	192		119	147		99	83

Motor part number *5	Output (kW)	KB2				H		LW	LK	KW	KH	RH	Mass (kg)	
		No brake		With brake		No brake	With brake						No brake	With brake
		Encoder connector JN2	Encoder connector JL10	Encoder connector JN2	Encoder connector JL10	With oil seal							With oil seal	
MHMG102U1 □□	1.0	127	130	155	158	105	116	45	41	8	7	18	6.2	7.8
MHMG152U1 □□	1.5	141	144	169	172								7.9	9.5

*5 The □ represents the motor structure. Please refer to page 8 for details.

Note: If high-speed response is required, lower the load inertia ratio to rotor inertia moment.

Dimensions are subject to change, so if you are using it for design purposes, please inquire for final dimensions.

Before using the product, be sure to read the "Instruction Manual" and carefully check the precautions to ensure proper use.

Environmental condition

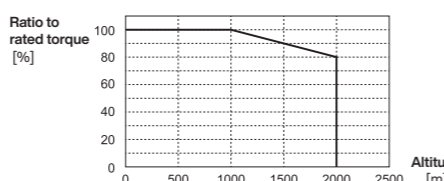
Item	Conditions
Operating temperature *1	0 °C to +60 °C (No freezing) (The rating will be derated if the temperature exceeds 40°C for models without oil seal, and if the temperature exceeds 20°C for models with oil seal. *3)
Operating Humidity	20 %RH to 85 %RH (No condensation *4)
Storage temperature *2	-20 °C to 65 °C (Guaranteed maximum temperature: 80 °C : 72 hours cumulatively. No condensation *4)
Storage humidity	20 %RH to 85 %RH (No condensation *4)
Vibration resistance	Motor only 49 m/s ² (5 G) or less when rotating, 24.5 m/s ² (2.5 G) or less when stopped
Shock Resistant	Motor only 98 m/s ² (10 G) or less
Protection class (motor only)	<input type="checkbox"/> 80 or less : IP65 equivalent *5 (excluding output shaft rotating part and connector) <input type="checkbox"/> 100 or more : IP67 equivalent *5 (excluding the connector cable connection part, the driver side of the cable, and the output shaft pass-through part in condition combined with the specified connector)
Altitude	Less than 2000 m above sea level. However, if exceeds 1000 m, please use the reduced rating shown on the right. 

*1 The operating temperature is the temperature 5 cm away from the motor.
 *2 This is allowable temperature for short periods of time, such as during transportation.
 *3 For derating, refer to 2.2.4 (Specifications) in the Instruction Manual (General).
 *4 Please note that as the temperature decreases, the humidity increases, making condensation more likely to occur.
 *5 IP65 and IP67 are protection ratings according to the IEC standard (IEC60529) and indicate that passed the specified test. That is not guarantee that the IP rating will be maintained during use.

<Note>

The initial settings for the rotation direction are defined as positive direction (CCW) and negative direction (CW). please note.

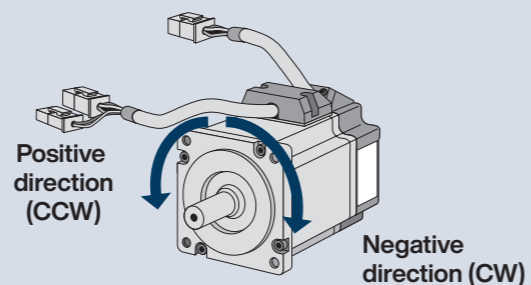

About the notes on the "Motor specifications" page

Note)1 A and B frame drivers do not have a built-in regenerative resistor. If regeneration occurs, please prepare an optional external regenerative resistor.

● At 100 V AC power supply

- The regenerative braking frequency indicates the allowable frequency when the motor decelerates to a stop from its rated speed.
- When a load is applied, the value in the table becomes $1/(m + 1)$. (m = load inertia/rotor inertia)
- The frequency of regenerative braking when the rated rotational speed is exceeded is inversely proportional to the square of (operating speed/rated speed).
- The power supply voltage is 115 VAC (at 100 VAC power supply). When the power supply voltage fluctuates, it is inversely proportional to the square of (operating power supply voltage/115) with respect to the value in the table.
- Please contact us if the operating rotation speed changes frequently or if the machine is constantly regenerating, such as in vertical feed.

● At 200 V AC power supply

- The regenerative braking frequency indicates the allowable frequency when the motor decelerates to a stop from its rated speed.
- When a load is applied, the value becomes $1/(m + 1)$ of the value in the table. (m = load inertia/rotor inertia)
- The frequency of regenerative braking when the rated rotational speed is exceeded is inversely proportional to the square of (operating speed/rated speed).
- The power supply voltage is 230 VAC (when using a 200 VAC power supply). When the power supply voltage fluctuates, it is inversely proportional to the square of (operating power supply voltage/230) with respect to the value in the table.
- Please contact us if the operating rotation speed changes frequently or if the machine is constantly regenerating, such as in vertical feed.

Note)2 There are no restrictions on the regeneration frequency as long as the effective torque is within the rated torque.

Note)3 Please contact us if the load inertia ratio exceeds the listed value.

Note)4 The release time is the value for DC switching using a varistor.

Allowable load of the output shaft

Radial load" refers to the load applied to the output shaft in the radial direction. This occurs when the other machine is connected with a chain or belt, but does not occur when it is directly connected to a coupling. As shown in the figure below, the allowable value is set by the load applied to the LR/2 position of the output shaft. Also, thrust load refers to the load applied to the output shaft in the thrust direction.

Radial load and thrust load greatly affect the life and strength of the bearing, so please be careful that the load during operation does not exceed the allowable radial load and allowable thrust load listed on each page.

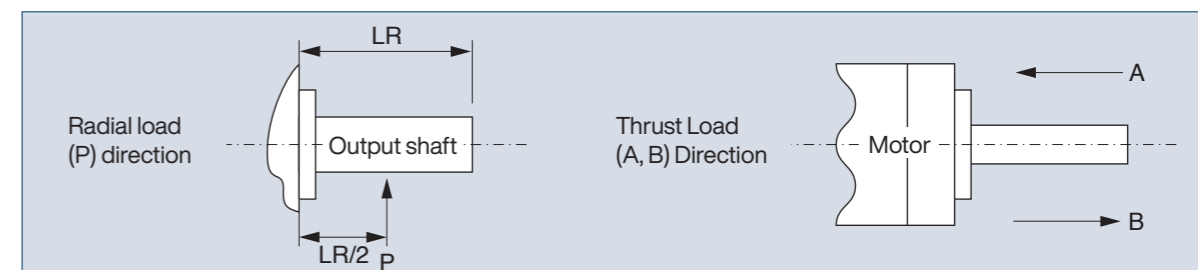

Motor built-in holding brake

It is used to hold the workpiece (movable part) from falling due to gravity when the power to the driver is cut off, such as in applications where a motor drives a vertical axis.

The built-in brake of the motor is only used for "holding" purposes to maintain a stopped state. Do not use it for "braking" to stop a moving load.

● BRK-OFF signal output timing

- For information on the timing of releasing the brake when the power is turned on, the braking timing at Servo-Off or alarm while the motor is rotating, etc., please download the instruction manual from our website and refer to it.
- When the servo is turned off while the motor is rotating, or when an alarm occurs, the time from when the motor becomes free from the excited state until the BRKOFF signal turns off (brake operates) can be set in Pr4.38 (mechanical brake operation setting during operation). For more information, please download and refer to the instruction manual from our website.

<Note>

- When operating a motor with a built-in brake, brake lining noise (rattle, etc.) may occur, but this does not affect functionality.
- When the brake coil is energized (brake is open), leakage magnetic flux may occur from the shaft end, etc. Please be careful when using magnetic sensors etc. near the motor.

● Motor built-in holding brake specification

Motor series	Motor output	Static friction torque N·m	Suction time mzs	Release time ms	Excitation current DC A (cold)	Release voltage DC V / Excitation voltage DC V	Allowable work amount per braking J	Allowable total work amount J	Allowable angular acceleration rad/s ²	
MHMG (80 mm sq. or less)	50 W, 100 W	0.38 or more	35 or less	20 or less*1	0.30	1 or more / 24±2.4	39.2	4.9×10 ³	30000	
	200 W, 400 W	1.6 or more	50 or less		0.36		105	44.1×10 ³		
	750 W, 1000 W	3.8 or more	70 or less		0.42		185	80×10 ³		
MMSG (100 mm sq.)	1000 W, 1500 W	8.0 or more	50 or less	15 or less*2	0.81	2 or more / 24±2.4	600	5.0×10 ⁵	10000	
MDMG (130 mm sq.)		13.7 or more	100 or less	50 or less*3			0.79	1470		2.16×10 ⁶
MHMG (130 mm sq.)										
MGMG (130 mm sq.)										

*1 Used varistor :Nippon Chemi-Con Corporation TND14V271K , DC cut-off

*2 Used varistor :SEMITEC Corporation Z15D151, DC cut-off

*3 Used varistor :KOA Corporation NVD07SCD083 , DC cut-off

- The suction time and release time represent the delay time of brake activation.
- The release time is the value for DC switching using a varistor.
- The above figures are representative characteristics(Static friction torque, release voltage and excitation voltage are excluded.)
- The backlash of the built-in holding brake is 2° or less when shipped.
- The lifespan of acceleration/deceleration times based on the above allowable angular acceleration is 10 million times (the number of accelerations/decelerations until the brake backlash suddenly changes)
- Supply power for the motor brake from a power source different from the power source for driver connectors X1, X2, X3, X4, X5, and X6.

About EU Directives/UK Standards

EU Directives/UK Standards apply to all electronic products exported to the European Union (EU) that have specific functionality and are sold directly to consumers. Products must comply with unified safety standards and must be affixed with the CE marking, which indicates compliance.

At our company, we have achieved compliance with the relevant standards of the EU Low Voltage Directive/UK Low Voltage Regulation, in order to facilitate the compliance of the machines and equipment that are incorporated with the EU Directives.

Compliance with EU EMC Directive/UK EMC Regulations

For our servo systems, we determine the model (conditions) such as the installation distance and wiring between the driver and motor, and use that model to comply with the relevant standards of the EU EMC Directive/UK EMC Regulation. When installed in an actual machine or device, wiring conditions, grounding conditions, etc. may not be the same as the model. For this reason, in order to ensure that machinery and equipment comply with the EU EMC Directive/UK EMC Regulations (especially regarding unnecessary radiation noise and noise terminal voltage), it is necessary to measure the final machinery and equipment that incorporates the driver and motor.

Compliance with UL standards

By complying with the installation conditions ① and ② below, it becomes a UL61800-5-1 (File No. E164620) standard certified product.

- ① Use the driver under the environment of pollution degree 2 as specified in IEC60664-1 (e.g. installing inside IP54 control panel).
- ② Be sure to connect a UL-certified (LISTED, UL marking) wiring circuit breaker and a UL-certified (LISTED, UL marking) fuse between the power supply and the noise filter. For the rated current of the wiring circuit breaker/fuse, refer to "List of applicable peripherals" on page 11. For wiring, use copper conductor wire with a temperature rated of 75°C only.
- ③ Overload protection level
Overload protection level The overload protection function operates based on the motor's time limit characteristics when the effective current reaches or exceeds 115% of the rated current.

Overload protection time characteristic

• Motor Type : □ 40 mm MHMG

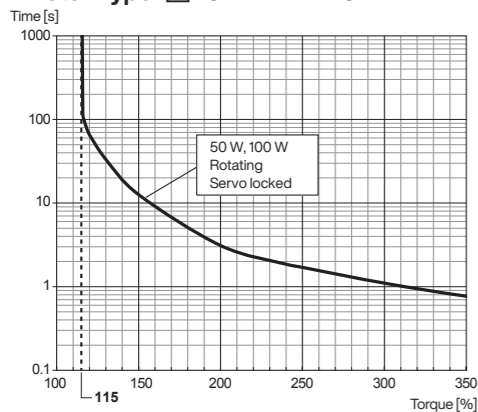

• Motor Type : □ 60 mm MHMG

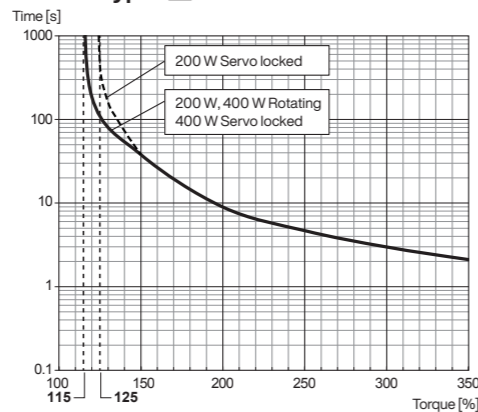

• Motor Type : □ 80 mm MHMG

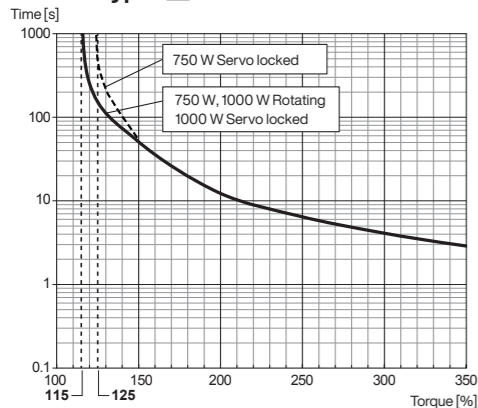

• Motor Type : □ 130 mm MHMG

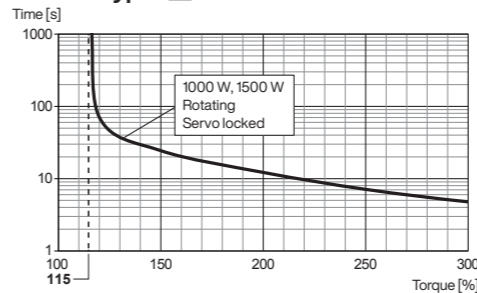

• Motor Type : □ 100 mm MSMG

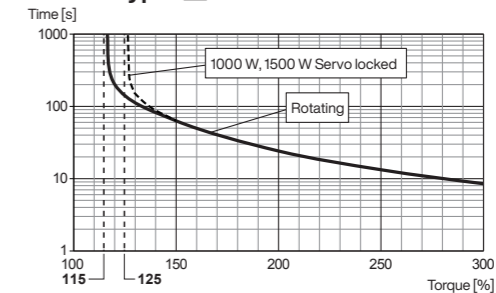

• Motor Type : □ 130 mm MDMG

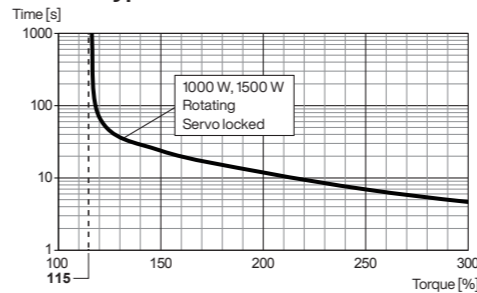

• Motor Type : □ 130 mm MGMG

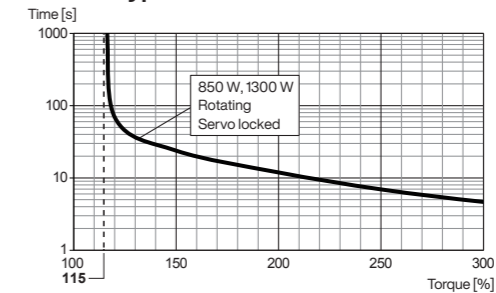

Conformed Standards

	Driver	Motor
EU/UK Standards	EU EMC Directive/UK EMC Regulation Related Standards EN 55011(Group1, Class A) EN 61000-6-2 EN 61000-6-4 EN 61800-3(CategoryC2, Second environment)	—
	EU Low Voltage Directive/UK Low Voltage Regulation Related Standards EN 61800-5-1	EN 60034-1 EN 60034-5
	Machinery directive Related standard [Functional Safety **] EN ISO 13849-1:2015 (Category 3 PL e) EN 61508(SIL3) EN IEC 62061(maximum SIL 3) EN 61800-5-2(SIL3, STO) EN 61326-3-1 IEC 60204-1(stop category 0)	—
UL Standards	UL 61800-5-1 (E164620)	UL 1004-1, UL1004-6 (E327868)
CSA standards	C22.2 No.274	C22.2 No.100
Korea Radio Law (KC) *2	KN 11 KN 61000-4-2,3,4,5,6,8,11	—

To achieve a safety level of SIL3 and PL e, the STO circuit must be diagnosed (up to 3 months between diagnostics). If the STO circuit is not diagnosed, it will be SIL2 and PL d.

- IEC : International Electrotechnical Commission
- EN : European Norm
- EMC : Electromagnetic Compatibility
- UL : Underwriters Laboratories
- CSA : Canadian Standards Association

● When exporting, please be sure to comply with the laws and regulations of the destination country.

*1 A7NE and A7BE types do not comply with functional safety standards.

*2 Notes on the Korean Radio Law
This device is a commercial electromagnetic wave generator (Class A) and is intended for use in locations other than the home. Sellers and users should be aware of this.

A 급 기기 (업무용 방송통신기자재)
이 기기는 업무용(A 급) 전자파적합기기로서 판매자 또는 사용자는 이 점을 주의하시기 바라며, 가정외의 지역에서 사용하는 것을 목적으로 합니다.
(대상기종 : Servo Driver)

■ Servo driver

MADN					
Part number	Type	Frame	Interface	Functions and specifications	Page
MADN061BE	A7BE	A	EtherCAT	Standard type	12-22
MADN061BF	A7BF			Multifunctional type	
MADN061NE	A7NE	A	RTEX	Standard type	12-22
MADN061NF	A7NF			Multifunctional type	
MADN065BE	A7BE	A	EtherCAT	Standard type	12-22
MADN065BF	A7BF			Multifunctional type	
MADN065BRH	A7BR			Gantry control	—
MADN065BRT				Pressure control	
MADN065BRU		Displacement control			
MADN065NE	A7NE	A	RTEX	Standard type	
MADN065NF	A7NF			Multifunctional type	
MADN065NRH	A7NR			Gantry control	—
MADN065NRT				Pressure control	
MADN065NRU		Displacement control			
MADN081BE	A7BE	A	EtherCAT	Standard type	
MADN081BF	A7BF			Multifunctional type	
MADN081NE	A7NE	A	RTEX	Standard type	12-22
MADN081NF	A7NF			Multifunctional type	
MADN085BE	A7BE	A	EtherCAT	Standard type	12-22
MADN085BF	A7BF			Multifunctional type	
MADN085BRH	A7BR			Gantry control	—
MADN085BRT				Pressure control	
MADN085BRU		Displacement control			
MADN085NE	A7NE	A	RTEX	Standard type	
MADN085NF	A7NF			Multifunctional type	
MADN085NRH	A7NR			Gantry control	—
MADN085NRT				Pressure control	
MADN085NRU		Displacement control			

MBDN					
Part number	Type	Frame	Interface	Functions and specifications	Page
MBDN121BE	A7BE	B	EtherCAT	Standard type	12-22
MBDN121BF	A7BF			Multifunctional type	
MBDN121NE	A7NE	B	RTEX	Standard type	12-22
MBDN121NF	A7NF			Multifunctional type	
MBDN125BE	A7BE	B	EtherCAT	Standard type	12-22
MBDN125BF	A7BF			Multifunctional type	
MBDN125BRH	A7BR			Gantry control	—
MBDN125BRT				Pressure control	
MBDN125BRU		Displacement control			
MBDN125NE	A7NE	B	RTEX	Standard type	
MBDN125NF	A7NF			Multifunctional type	
MBDN125NRH	A7NR			Gantry control	—
MBDN125NRT				Pressure control	
MBDN125NRU		Displacement control			

■ Servo driver

MCDN					
Part number	Type	Frame	Interface	Functions and specifications	Page
MCDN201BE	A7BE	C	EtherCAT	Standard type	12-22
MCDN201BF	A7BF			Multifunctional type	
MCDN201NE	A7NE	C	RTEX	Standard type	12-22
MCDN201NF	A7NF			Multifunctional type	
MCDN205BE	A7BE	C	EtherCAT	Standard type	12-22
MCDN205BF	A7BF			Multifunctional type	
MCDN205BRH	A7BR			Gantry control	—
MCDN205BRT				Pressure control	
MCDN205BRU		Displacement control			
MCDN205NE	A7NE	C	RTEX	Standard type	
MCDN205NF	A7NF			Multifunctional type	
MCDN205NRH	A7NR			Gantry control	—
MCDN205NRT				Pressure control	
MCDN205NRU		Displacement control			
MCDN245BE	A7BE	C	EtherCAT	Standard type	
MCDN245BF	A7BF			Multifunctional type	
MCDN245BRH	A7BR			Gantry control	—
MCDN245BRT				Pressure control	
MCDN245BRU		Meandering control, GAP control supported			
MCDN245NE	A7NE	C	RTEX	Standard type	
MCDN245NF	A7NF			Multifunctional type	
MCDN245NRH	A7NR			Gantry control	—
MCDN245NRT				Pressure control	
MCDN245NRU		Meandering control, GAP control supported			

MDDN					
Part number	Type	Frame	Interface	Functions and specifications	Page
MDDN405BE	A7BE	D	EtherCAT	Standard type	12-22
MDDN405BF	A7BF			Multifunctional type	
MDDN405BRH	A7BR			Gantry control	—
MDDN405BRT				Pressure control	
MDDN405BRU		Displacement control			
MDDN405NE	A7NE	D	RTEX	Standard type	
MDDN405NF	A7NF			Multifunctional type	
MDDN405NRH	A7NR			Gantry control	—
MDDN405NRT				Pressure control	
MDDN405NRU		Displacement control			

■ Servo motor

MDMG <Medium inertia>							
Part number	Name	Shaft specification	Holding brake		Oil Seal		Page
			without	with	with	with (protective lip)	
MDMG102U1C5	MDMG 1000 W Motor	Round	●		●		34
MDMG102U1C6			●		●		
MDMG102U1C7			●			●	
MDMG102U1C8			●			●	
MDMG102U1D5				●	●		
MDMG102U1D6				●	●		
MDMG102U1D7				●		●	
MDMG102U1D8				●		●	
MDMG102U1G5		With Key With Tap	●		●		
MDMG102U1G6			●		●		
MDMG102U1G7			●			●	
MDMG102U1G8			●			●	
MDMG102U1H5				●	●		
MDMG102U1H6				●	●		
MDMG102U1H7				●		●	
MDMG102U1H8				●		●	
MDMG152U1C5	MDMG 1500 W Motor	Round	●		●		34
MDMG152U1C6			●		●		
MDMG152U1C7			●			●	
MDMG152U1C8			●			●	
MDMG152U1D5				●	●		
MDMG152U1D6				●	●		
MDMG152U1D7				●		●	
MDMG152U1D8				●		●	
MDMG152U1G5		With Key With Tap	●		●		
MDMG152U1G6			●		●		
MDMG152U1G7			●			●	
MDMG152U1G8			●			●	
MDMG152U1H5				●	●		
MDMG152U1H6				●	●		
MDMG152U1H7				●		●	
MDMG152U1H8				●		●	

■ Servo motor

MGMG <Medium inertia>							
Part number	Name	Shaft specification	Holding brake		Oil Seal		Page
			without	with	with	with (protective lip)	
MGMG092U1C5	MGMG 850 W Motor	Round	●		●		36
MGMG092U1C6			●		●		
MGMG092U1C7			●			●	
MGMG092U1C8			●			●	
MGMG092U1D5				●	●		
MGMG092U1D6				●	●		
MGMG092U1D7				●		●	
MGMG092U1D8				●		●	
MGMG092U1G5		With Key With Tap	●		●		
MGMG092U1G6			●		●		
MGMG092U1G7			●			●	
MGMG092U1G8			●			●	
MGMG092U1H5				●	●		
MGMG092U1H6				●	●		
MGMG092U1H7				●		●	
MGMG092U1H8				●		●	
MGMG132U1C5	MGMG 1300 W Motor	Round	●		●		36
MGMG132U1C6			●		●		
MGMG132U1C7			●			●	
MGMG132U1C8			●			●	
MGMG132U1D5				●	●		
MGMG132U1D6				●	●		
MGMG132U1D7				●		●	
MGMG132U1D8				●		●	
MGMG132U1G5		With Key With Tap	●		●		
MGMG132U1G6			●		●		
MGMG132U1G7			●			●	
MGMG132U1G8			●			●	
MGMG132U1H5				●	●		
MGMG132U1H6				●	●		
MGMG132U1H7				●		●	
MGMG132U1H8				●		●	

● This product is for industrial equipment. It cannot be used at general home.

● This product is for industrial equipment. It cannot be used at general home.

■ Servo motor

MHMG <High inertia>									
Part number	Name	Shaft specification	Holding brake		Oil Seal			Page	
			without	with	without	with	with (protective lip)		
MHMG011U1A2	MHMG 100 W Motor	Round	●	●	●			24	
MHMG011U1B2			●	●	●				
MHMG011U1C2			●			●			
MHMG011U1D2			●	●		●			
MHMG011U1S2		With Key With Tap	●		●				
MHMG011U1T2			●	●	●				
MHMG011U1U2			●			●			
MHMG011U1V2			●	●		●			
MHMG012U1A2		Round	●		●				
MHMG012U1B2			●	●	●				
MHMG012U1C2			●			●			
MHMG012U1D2			●	●		●			
MHMG012U1S2			With Key With Tap	●		●			
MHMG012U1T2				●	●	●			
MHMG012U1U2		●			●				
MHMG012U1V2		●	●		●				
MHMG021U1A2	MHMG 200 W Motor	Round	●		●		26		
MHMG021U1B2			●	●	●				
MHMG021U1C2			●			●			
MHMG021U1D2		●	●		●				
MHMG021U1S2		With Key With Tap	●		●				
MHMG021U1T2			●	●	●				
MHMG021U1U2			●			●			
MHMG021U1V2		●	●		●				
MHMG022U1A2		Round	●		●				
MHMG022U1B2			●	●	●				
MHMG022U1C2			●			●			
MHMG022U1D2			●	●		●			
MHMG022U1S2	With Key With Tap		●		●				
MHMG022U1T2			●	●	●				
MHMG022U1U2		●			●				
MHMG022U1V2	●	●		●					
MHMG041U1A2	MHMG 400 W Motor	Round	●		●		26		
MHMG041U1B2			●	●	●				
MHMG041U1C2			●			●			
MHMG041U1D2			●	●		●			
MHMG041U1S2		With Key With Tap	●		●				
MHMG041U1T2			●	●	●				
MHMG041U1U2			●			●			
MHMG041U1V2			●	●		●			
MHMG042U1A2		Round	●		●				
MHMG042U1B2			●	●	●				
MHMG042U1C2			●			●			
MHMG042U1D2			●	●		●			
MHMG042U1S2	With Key With Tap	●		●					
MHMG042U1T2		●	●	●					
MHMG042U1U2		●			●				
MHMG042U1V2		●	●		●				
MHMG082U1A2	MHMG 750 W Motor	Round	●		●		28		
MHMG082U1B2			●	●	●				
MHMG082U1C2			●			●			
MHMG082U1D2			●	●		●			
MHMG082U1S2		With Key With Tap	●		●				
MHMG082U1T2			●	●	●				
MHMG082U1U2			●			●			
MHMG082U1V2			●	●		●			

● This product is for industrial equipment. It cannot be used at general home.

■ Servo motor

MHMG <High inertia>									
Part number	Name	Shaft specification	Holding brake		Oil Seal			Page	
			without	with	without	with	with (protective lip)		
MHMG092U1A2	MHMG 1000 W Motor	Round	●		●			28	
MHMG092U1B2			●	●	●				
MHMG092U1C2			●			●			
MHMG092U1D2			●	●		●			
MHMG092U1S2		With Key With Tap	●		●				
MHMG092U1T2			●	●	●				
MHMG092U1U2			●			●			
MHMG092U1V2			●	●		●			
MHMG102U1C5		Round	●			●			30
MHMG102U1C6			●			●			
MHMG102U1C7			●				●		
MHMG102U1C8			●				●		
MHMG102U1D5			●	●		●			
MHMG102U1D6			●	●		●			
MHMG102U1D7			●	●			●		
MHMG102U1D8			●	●			●		
MHMG102U1G5	With Key With Tap	●			●				
MHMG102U1G6		●			●				
MHMG102U1G7		●				●			
MHMG102U1G8		●				●			
MHMG102U1H5		●	●		●				
MHMG102U1H6		●	●		●				
MHMG102U1H7		●	●			●			
MHMG102U1H8		●	●			●			
MHMG152U1C5	MHMG 1500 W Motor	Round	●			●	30		
MHMG152U1C6			●			●			
MHMG152U1C7			●					●	
MHMG152U1C8			●					●	
MHMG152U1D5		●	●		●				
MHMG152U1D6		●	●		●				
MHMG152U1D7		●	●			●			
MHMG152U1D8		●	●			●			
MHMG152U1G5		With Key With Tap	●			●			
MHMG152U1G6			●			●			
MHMG152U1G7			●					●	
MHMG152U1G8			●					●	
MHMG152U1H5	●	●		●					
MHMG152U1H6	●	●		●					
MHMG152U1H7	●	●			●				
MHMG152U1H8	●	●			●				
MHMG5AZU1A2	MHMG 50 W Motor	Round	●		●		24		
MHMG5AZU1B2			●	●	●				
MHMG5AZU1C2			●			●			
MHMG5AZU1D2			●	●		●			
MHMG5AZU1S2		With Key With Tap	●		●				
MHMG5AZU1T2			●	●	●				
MHMG5AZU1U2			●			●			
MHMG5AZU1V2			●	●		●			

● This product is for industrial equipment. It cannot be used at general home.

■ Servo motor

MSMG <Low inertia>								
Part number	Name	Shaft specification	Holding brake		Oil Seal		Page	
			without	with	with	with (protective lip)		
MSMG102U1C5	MSMG 1000 W Motor	Round	●		●		32	
MSMG102U1C6			●		●			
MSMG102U1C7			●			●		
MSMG102U1C8			●			●		
MSMG102U1D5				●		●		
MSMG102U1D6				●		●		
MSMG102U1D7				●				●
MSMG102U1D8				●				●
MSMG102U1G5		With Key With Tap	●		●			
MSMG102U1G6			●		●			
MSMG102U1G7			●			●		
MSMG102U1G8			●			●		
MSMG102U1H5				●		●		
MSMG102U1H6				●		●		
MSMG102U1H7				●				●
MSMG102U1H8				●				●
MSMG152U1C5	MSMG 1500 W Motor	Round	●		●		32	
MSMG152U1C6			●		●			
MSMG152U1C7			●			●		
MSMG152U1C8			●			●		
MSMG152U1D5				●		●		
MSMG152U1D6				●		●		
MSMG152U1D7				●				●
MSMG152U1D8				●				●
MSMG152U1G5		With Key With Tap	●		●			
MSMG152U1G6			●		●			
MSMG152U1G7			●			●		
MSMG152U1G8			●			●		
MSMG152U1H5				●		●		
MSMG152U1H6				●		●		
MSMG152U1H7				●				●
MSMG152U1H8				●				●

● This product is for industrial equipment. It cannot be used at general home.

List of oversea sales offices

[Panasonic Industry Co., Ltd. Sales Office of Motors]

(May 01, 2025)

Region	Company Name [Category]	City	Address	TEL
				FAX
U.S.A	Panasonic Industrial Devices Sales Company of America [Sales office]	New Jersey	Two Riverfront Plaza, 10th Floor Newark, NJ 07102-5490, U.S.A	+1-800-344-2112
				—
			Web site	http://na.industrial.panasonic.com/
Brazil	Panasonic Do Brasil Limitada [Sales office]	Sao Paulo	Rua Alexandre Dumas, 1711 - 8 Andar torre 11, Chácara Santo Antônio, São Paulo SP Brazil	—
				—
			Web site	http://www.panasonic-electric-works.com/
Germany	Panasonic Electric Works Europe AG European Headquarters [Sales office]	Munich	Caroline-Herschel-Straße 100, 85521 Ottobrunn, Germany	+49-89-45354-1000
				+49-89-45354-2111
			Web site	http://www.panasonic-electric-works.com/
France	Panasonic Electric Works Sales Western Europe B.V. [Sales office]	Verrières- Le-Buisson	10, rue des petits ruisseaux, 91370 Verrières- Le-Buisson, France	+ 33 (0) 1-60-13-5757
				+ 33 (0) 1-60-13-5758
			Web site	http://www.panasonic-electric-works.fr/
Italy	Panasonic Industry Italia s.r.l. [Subsidiary]	Verona	Via del Commercio 3-5, 37012 Bussolengo- Fertina, Italy	+39-45-6752711
				+39-45-6700444
			Web site	http://www.panasonic-electric-works.it/
Great Britain	Panasonic Electric Works UK Ltd. [Sales office]	Milton Keynes	Sunrise Parkway, Linford Wood, Milton Keynes MK14 6LF, United Kingdom	+44-1908-231-555
				+44-1908-231-599
			Web site	http://www.panasonic-electric-works.co.uk/
Austria	Panasonic Industry Austria GmbH [Sales office]	Biedermannsdorf	Josef Madersperger Straße 2, 2362 Biedermannsdorf, Austria	+43-2236-26846-7
				+43-2236-46133
			Web site	http://www.panasonic-electric-works.at/
Poland	Panasonic Industry Poland [Sales office]	Warszawa	Ul. Dowborczykow 25, 90-019 Lodz, Poland	+48-42-230-9633
				—
			Web site	http://www.panasonic-electric-works.pl/
Benelux	Panasonic Electric Works Sales Western Europe B.V. [Sales office]	PJ Best	De Rijn 4, 5684 PJ Best, Netherlands	+31(0)499-37-27-27
				+31(0)499-37-21-85
			Web site	http://www.panasonic-electric-works.nl/
Czech Republic	Panasonic Electric Works Europe AG Czech Representative Office [Sales office]	Brno	Veveri 3163/111, 61600 Brno, Czech Republic	+420-541-217-001
				+420-541-217-101
			Web site	http://www.panasonic-electric-works.cz/
Spain	Panasonic Industry Iberia S.A. [Sales office]	Madrid	Barajas Park, San Severo, 20, 28042 Madrid, Spain	+34-913293875
				+34-913292976
			Web site	http://www.panasonic-electric-works.es/
Hungary	Panasonic Electric Works Europe AG Hungarian Representative Office [Sales office]	Budapest	Neumann Janos u. 1., 1117 Budapest, Hungary	+43 2236 26846-25
				+43 2236 46133
			Web site	http://www.panasonic-electric-works.at/

List of oversea sales offices

Region	Company Name [Category]	City	Address	TEL	
				FAX	
Switzerland	Panasonic Industry Switzerland AG [Sales office]	Rotkreuz	Grundstraße 8, 6343 Rotkreuz ZG, Switzerland	+41(0)417997054	
				+41(0)417997055	
			Web site	http://www.panasonic-electric-works.ch/	
Turkey	DMY Elektrik Otomasyon Aydınlatma San. ve Tic. A.Ş. [Distributors]	Istanbul	Emek Mah. Ordu Cad. No:49/51 34785 Sancaktepe /Istanbul, Türkiye	+90 216 394 01 55	
				—	
			e-mail	info@dmyeo.com.tr	
China	Panasonic Hong Kong Co., Limited (PHK) Panasonic Industrial Devices Sales (Hong Kong) Co., Ltd. [Sales office]	Hong Kong	Level 9, Tower II, Grand Century Place, 193 Prince Edward Road West, Mongkok, Kowloon, Hong Kong	+852-2367-0181	
				+852-2865-3697	
	Panasonic Industry (China) Co.,Ltd. [Sales office]	Shanghai	15F, 1601-02, No.18, Lane 666, Haiyang West Road, Pudong New District, Shanghai, 200126, China	+86-21-38552000	
				+86-21-38552370	
				Web site	https://industrial.panasonic.com/ea/
	Panasonic Industry (China) Co.,Ltd. [Sales office]	Shenzhen	10F, Tower D, China Resources Land Building, No.91 Kefa Road, Nanshan District, Shenzhen, 518057, China	+86-755-22074488	
+86-755-22074498					
			Web site	https://industrial.panasonic.com/ea/	
India	Panasonic Life Solutions India Private Limited INDD - Industrial Devices Division- Sales & Marketing (Gurgaon(HQ)) [Sales office]	Delhi	12th Floor, Ambience Corporate Office, Tower-2, Ambience Island, NH-8, Gurgaon-122002, Haryana, India	+91-124-4871300	
				+91-124-4751333	
	Panasonic Life Solutions India Private Limited INDD - Industrial Devices Division- Sales & Marketing (Bangalore Office) [Sales office]	Bengaluru	"J.P. Chambers" 2nd Floor, #276/22-1, 46th Cross, 5th Block, Jayanagar, Bangalore - 560041	+91-124-6676-311	
				—	
	Panasonic Life Solutions India Private Limited INDD - Industrial Devices Division- Sales & Marketing (Mumbai Office) [Sales office]	Mumbai	502 / 503, Windfall, Sahar Plaza Complex, JB Nagar Andheri Kurla Road, Andheri (E) Mumbai - 400059, India	+91-124-4871300 ext : 1626	
				—	
	Panasonic Life Solutions India Private Limited INDD - Industrial Devices Division- Sales & Marketing (Chennai Office) [Sales office]	Chennai	Spic House Ann exe, 6th Floor, No.88, Mount Road, Guindy, Chennai - 600032, Tamilnadu	+91-44-6108-9300	
				—	
Panasonic Life Solutions India Private Limited INDD - Industrial Devices Division- Sales & Marketing (Pune Office) [Sales office]	Pune	Office No. 401 & 402, Godrej Eternia, Above At Home Centre, Next to Shopper's Stop, Shivaji Nagar, Mumbai Pune Road, Pune - 411005, Maharashtra India	+91-20-67449907		
			—		
Korea	Panasonic Industrial Devices Sales Korea Co., Ltd. [Sales office]	Seoul	114-38 Teheran-ro, Gangnam-gu, Seoul, 06176, Korea (1004 Daechi dong, DONGIL Tower 5-6F)	+82-2-795-9600 +82-2-2052-1053	
Taiwan	Panasonic Industrial Devices Sales Taiwan Co.,Ltd. [Sales office]	Taipei	12F, No. 9, SongGao Rd. , Taipei 110, Taiwan	+886-2-2757-1900 +886-2-2758-7502	

Region	Company Name [Category]	City	Address	TEL	
				FAX	
Singapore	Panasonic Industry Sales Asia Pacific [Head office]	Singapore	No.3 Bedok South Road, Singapore 469269	+65-6299-9181	
				+65-6390-3801	
Singapore	Intermech Machinery Pte.Ltd. [Distributors]	Singapore	2 Woodlands Sector 1 #03-25, Woodlands Spectrum 1 Singapore 738068	+65-6751-5088	
				e-mail	sales@intermech.com.sg
				Web site	http://www.intermech.com.sg
Malaysia	Panamech (Penang) Sdn. Bhd. [Distributors]	Penang	18, Persiaran Mahsuri 1/2, Sunway Tunas, Penang, 11900	+60-4-645-1635	
				+60-4-645-1639	
				e-mail	sales.pg@panamech.com.my
				Web site	http://panamech.com.my/
Malaysia	Carlo Controls (M) Sdn. Bhd. [Distributors]	Puchong	No.23, Jalan Puteri 4/1, Bandar Puteri, 47100 Puchong, Selangor Malaysia	+60-3-8064-7833	
				+60-3-8060-6733	
				e-mail	sales@carlocontrols.com
			Web site	https://www.carlocontrols.com/	
Thailand	Premier Automation Center Co.,Ltd. [Distributors]	Bangkok	87, Soi Lakrabang 30, Ladkrabang, Ladkrabang, Bangkok 10520	+66-2181-2299	
				+66-2181-2288	
				e-mail	sales@premier-ac.co.th
				Web site	http://www.premier-ac.co.th
	JW Tech Co., Ltd. [Distributors]	Bangkok	697 Soi Senavilla Village, Nawamin RD Klongchan, Bangkok, Bangkok 10240	+66-2733-7702	
				+66-2733-7703	
e-mail				info@jwtech.co.th	
			Web site	http://www.jwtech.co.th	
Sang Chai Meter Co., Ltd. [Distributors]	Bangkok	888 Phaholyothin Road, Samsennai, Phayathai, Bangkok 10120	+66-2299-3333		
			+66-2299-3000		
			e-mail	sales@sangchaimeter.com	
			Web site	https://www.sangchaimeter.com	
Indonesia	PT. Handal Yesindo Sejahtera [Distributors]	Surabaya	Jl. Raya Kutisari 8A, Surabaya 60291	+62-31-843-8844	
				+62-31-841-4333	
				e-mail	info@handalyesindo.com
			Web site	http://www.handalyesindo.com	
PT.Riasarana Electrindo [Distributors]	Jakarta	Jl. Prof. Dr. Latumenten Grogol Permai blok D No. 8-15 Jakarta 11460	+62-21-564-9178		
			+62-21-566-7405		
			Web site	http://www.risacorps.com	
Vietnam	Pavina Corporation [Distributors]	Ho Chi Minh	005 C1 Ly Thuong Kiet Blog, Vinh Vien Street, Ward 07, District 11, Ho Chi Minh	+84-8-39554457	
				+84-8-39550033	
				e-mail	pavina@sieuthitdong.com
				Web site	http://sieuthitdong.com
KSMC Co., Ltd. [Distributors]	Ha Noi	A10-No 06B, HH6, Viet Hung Urban Area, Long Bien, Ha Noi	+84-4-38771700		
			+84-4-38770229		
			e-mail	support@ksmc.com.vn	
			Web site	http://ksmc.com.vn	
Le Gia High Technology Joint Stock Company [Distributors]	Ho Chi Minh	90/2 (No. 221) Phan Huy Ich St, Ward 14, Go Vap Dist, Ho Chi Minh City, Vietnam	+84-28-7303-6860		
			—		
			e-mail	sales@levn.vn	
			Web site	http://www.LEvn.vn	
Philippines	Movaflex Designs Unlimited, Inc. [Distributors]	Manila	136 Calbayog Street, Mandaluyong City, Metro Manila 1552	+63-2-998-3881	
				+63-2-633-7526	
			e-mail	sales@movaflex.com	

Southeast Asia